

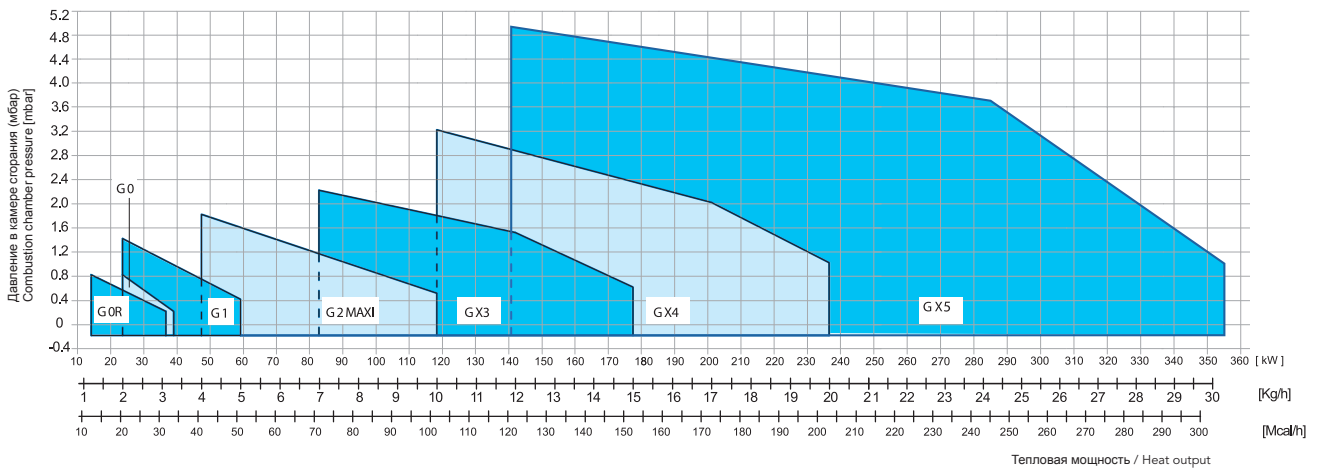

ОДНОСТУПЕНЧАТЫЕ 1 STAGE	kg/h		kW		⚡
	min	max	min	max	
G 0S 2001/2003* - G 0H 2001	2	3,3	23,7	39,1	1F
G 0SR 2001/2003* - G 0HR 2001	1,2	3,1	14,2	36,7	
G 1S 2001/2003* - G 1H 2001 - G 1R 2001/2003*	2	5	23,7	59,2	
G 2S MAXI* - G 2H MAXI	4	9,8	47,3	116	
G X3S - G X3H	7	15	83	178	
G X4S - G X4H	10	20	118	236	
G X5S - G X5H	12	30	142	355	

\* Имеются также в версии Low Nox  
\* Available also in Low NOx version

## ТЕПЛОВОЙ РАСХОД / РАЗМЕРЫ (мм) - FIRING RATES / OVERALL DIMENSIONS (mm)

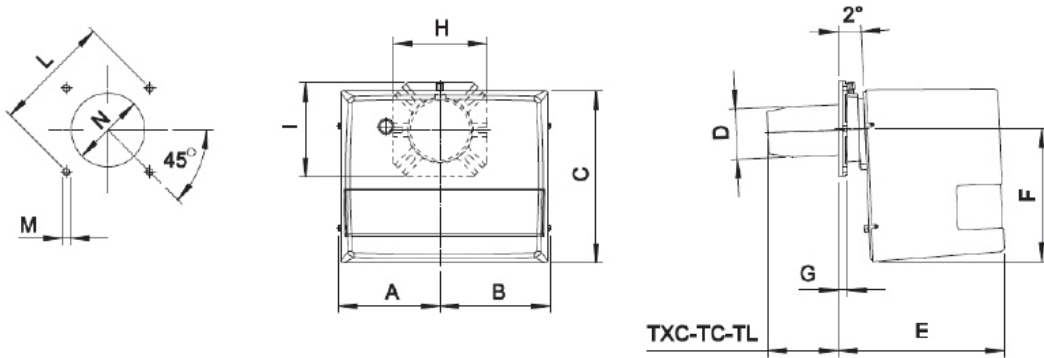

МОДЕЛЬ MODEL	A	B	C	D	E	F	G	H	I	L min	L *	L max	M	N min	N *	N max	TC	TL
	<b>G 0... 2001</b>	137	137	240	80	223	169	15	150	150	130	150	170	M8	90	110	130	112
<b>G 0...2003 **</b>	137	137	240	83	223	169	15	150	150	130	150	170	M8	90	110	130	112	152
<b>G 1... 2001</b>	157	170	275	80	265	210	15	150	150	130	150	170	M8	90	110	130	112	152
<b>G 1...2003</b>	157	170	275	83	265	210	15	150	150	130	150	170	M8	90	110	130	112	152
<b>G 2...MAXI</b>	157	170	275	90	265	210	15	150	150	130	150	170	M8	100	110	130	107	147
<b>G X3...</b>	182	192	318	110	306	248	17	200	200	160	170	226	M10	120	130	140	130	250
<b>G X4...</b>	182	192	318	124	306	248	17	200	200	170	205	226	M10	130	140	160	130	250
<b>G X5...</b>	210	218	400	130	461	310	18	200	200	205	220	226	M10	140	150	180	215	335

\* советовав/Suggested  
\*\* TXC = 77



ДВУХСТУПЕНЧАТАЯ С ПЕРЕПАДОМ ДАВЛЕНИЯ 2 STAGE WITH JUMP OF PRESSURE	kg/h		kW		⚡
	min	max	min	max	
G 1.22 2001	2	5	23,7	59,2	1F
G 2.22 MAXI*	4	9,8	47,3	116	
G X 3.22	7	15	83	178	
G X 4.22	10	20	118	236	
G X 5.22	12	30	142	355	

\* Имеются также в версии Low Nox  
\* Available also in Low NOx version

## ТЕПЛОВОЙ РАСХОД / РАЗМЕРЫ (мм) - FIRING RATES / OVERALL DIMENSIONS (mm)

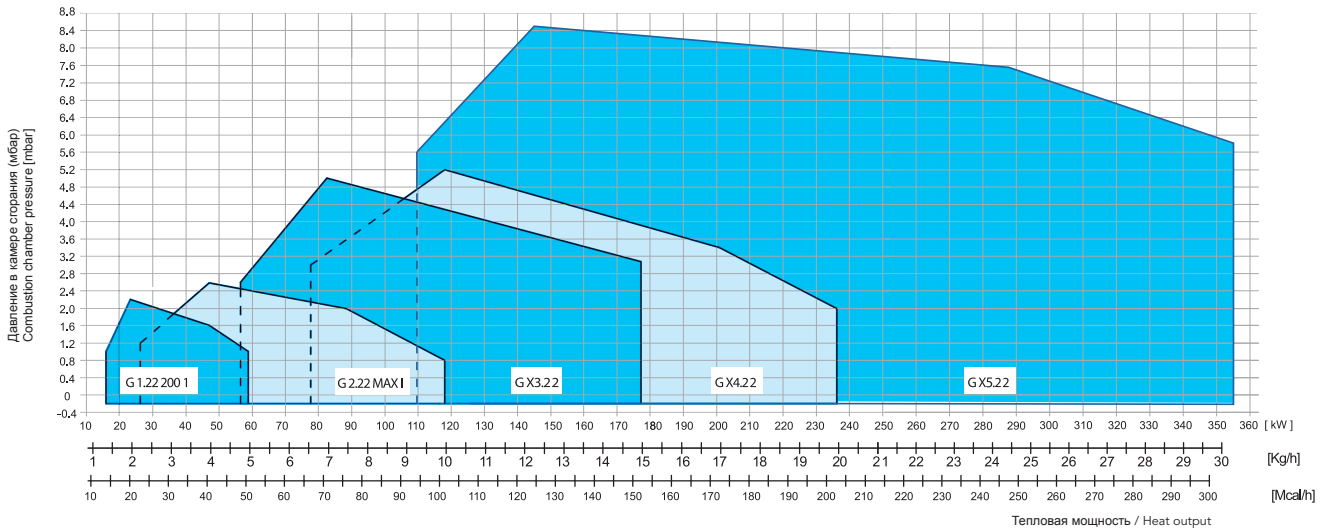
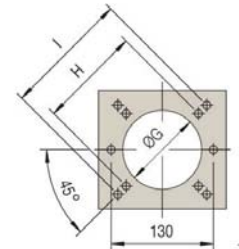
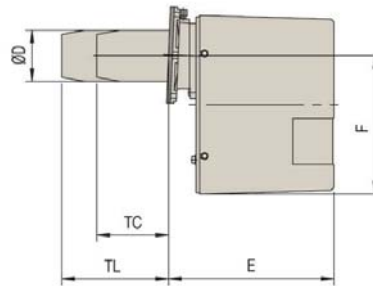
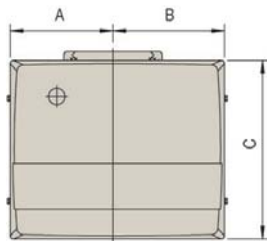

### МОДЕЛЬ MODEL

МОДЕЛЬ MODEL	A	B	C	D	E	F	G	H	I	TC	TL
<b>G 1.22 2001</b>	157	170	275	80	265	210	90	130	160	112	152
<b>G 2.22 MAXI</b>	157	170	275	90	265	210	100	130	160	112	152
<b>G X 3.22</b>	179	189	318	110	298	248	120	160	226	130	250
<b>G X 4.22</b>	179	189	318	124	298	248	135	160	226	130	250
<b>G X 5.22</b>	207	213	400	130	461	310	140	205	226	215	335



ОДНОСТУПЕНЧАТЫЕ для хлебопекарных печей  
1 STAGE for bakery ovens

	kg/h		kW		1F
	min	max	min	max	
G 1 F 2001	2	5	23,7	59,2	
G 2 F MAXI	4	9,8	47,3	116	
G X3 F	7	15	83	178	
G X4 F	10	20	118	236	
G X5 F	12	30	142	355	

## ТЕПЛОВОЙ РАСХОД / РАЗМЕРЫ (мм) - FIRING RATES / OVERALL DIMENSIONS (mm)

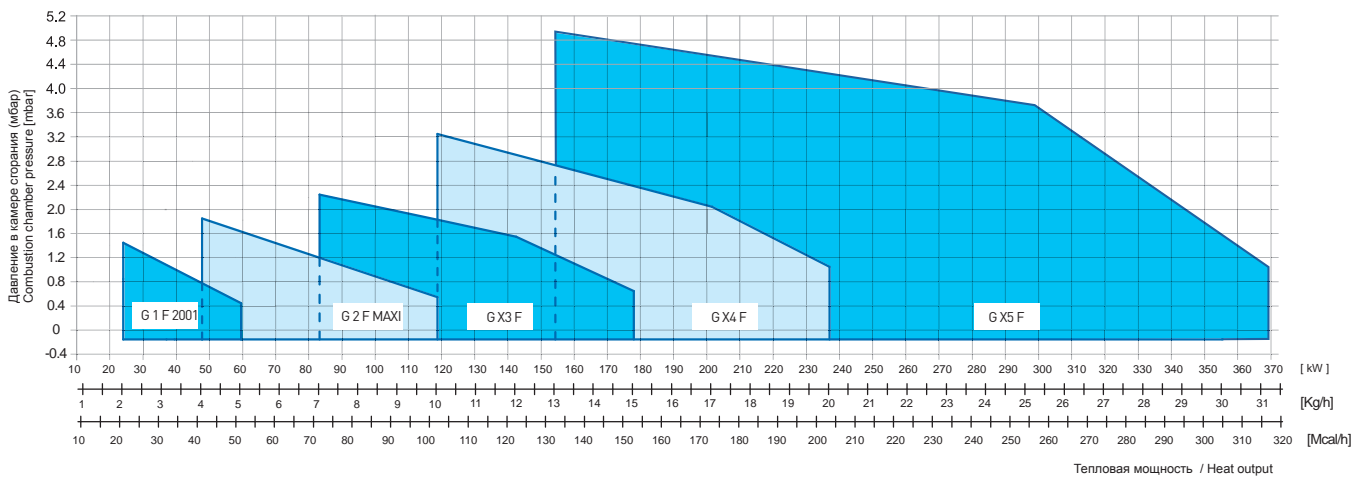
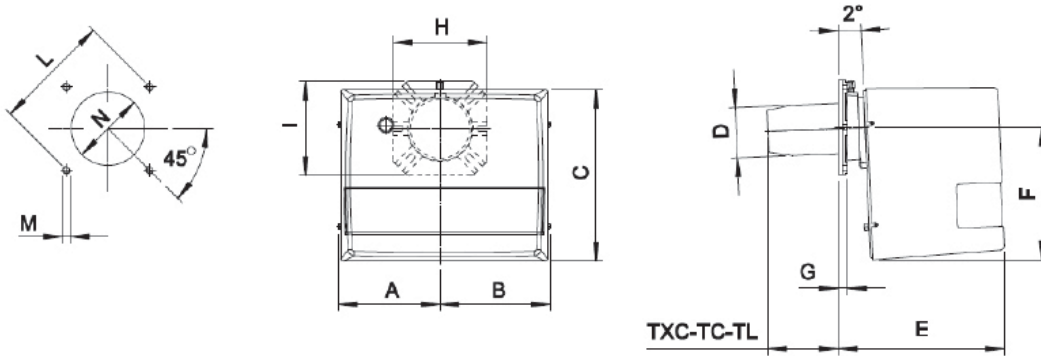

МОДЕЛЬ MODEL	* советовав/Suggested																	
	A	B	C	D	E	F	G	H	I	L min	L *	L max	M	N min	N *	N max	TC	TL
<b>G 1 F</b>	157	170	275	80	265	210	15	150	150	130	150	170	M8	90	110	130	112	152
<b>G 2 F MAXI</b>	157	170	275	90	265	210	15	150	150	130	150	170	M8	100	110	130	107	147
<b>G X3 F</b>	182	192	318	110	306	248	17	200	200	160	170	226	M10	120	130	140	130	250
<b>G X4 F</b>	182	192	318	124	306	248	17	200	200	170	205	226	M10	130	140	160	130	250
<b>G X5 F</b>	210	218	400	130	461	310	18	200	200	205	220	226	M10	140	150	180	215	335



ДВУХСТУПЕНЧАТЫЕ 2 STAGES	kg/h		kW		1F
	min	max	min	max	
GX 4/2	12	25	142	296	
GX 5/2	15	35	178	415	

## ТЕПЛОВОЙ РАСХОД / РАЗМЕРЫ (мм) - FIRING RATES / OVERALL DIMENSIONS (mm)

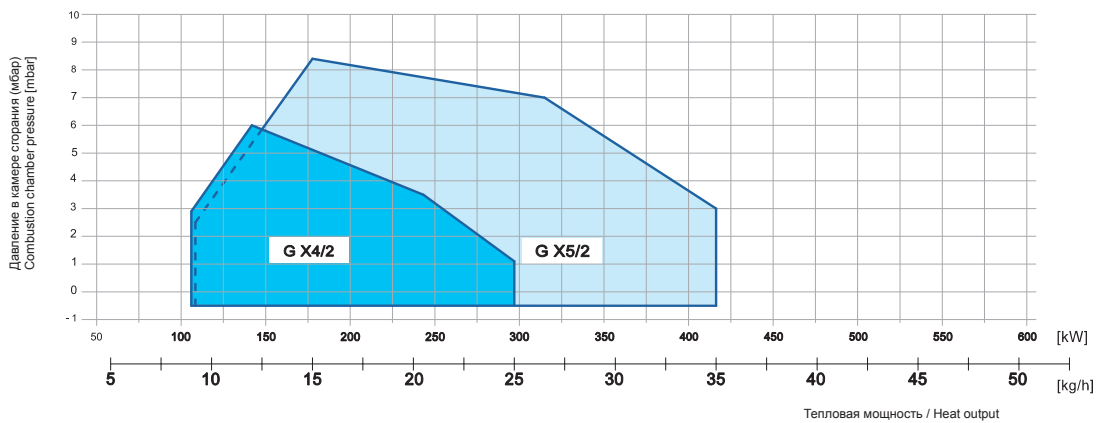
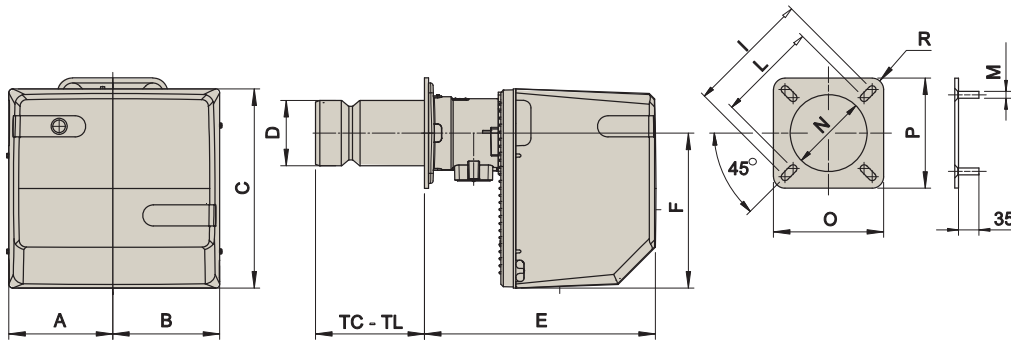

МОДЕЛЬ MODEL	A	B	C	D	E	F	I	L	N	O	P	R	TC	TL
G X4/2	179	189	318	124	306	248	226	160	135	200	200	R20	130	250
G X5/2	207	213	400	130	461	310	226	205	140	220	220	R30	215	335

# СЕРИЯ FGP

ДВУХСТУПЕНЧАТЫЕ ОТ 237 ДО 1740 кВт / 2 stages from 237 up to 1740 kW



ДВУХСТУПЕНЧАТЫЕ 2 STAGES	kg/h		kW		3F
	min	max	min	max	
FGP 50/2	20	50	237	592	3F
FGP 70/2	35	70	406	812	
FGP 100/2	40	100	464	1160	
FGP 120/2	60	120	696	1392	
FGP 150/2	75	150	870	1740	

## ТЕПЛОЙ РАСХОД / РАЗМЕРЫ (мм) - FIRING RATES / OVERALL DIMENSIONS (mm)

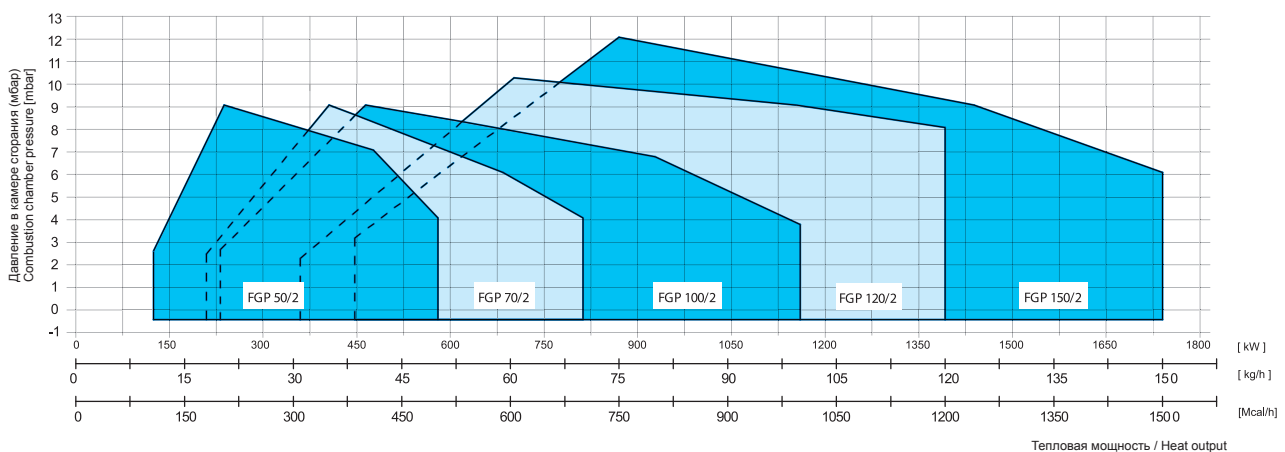
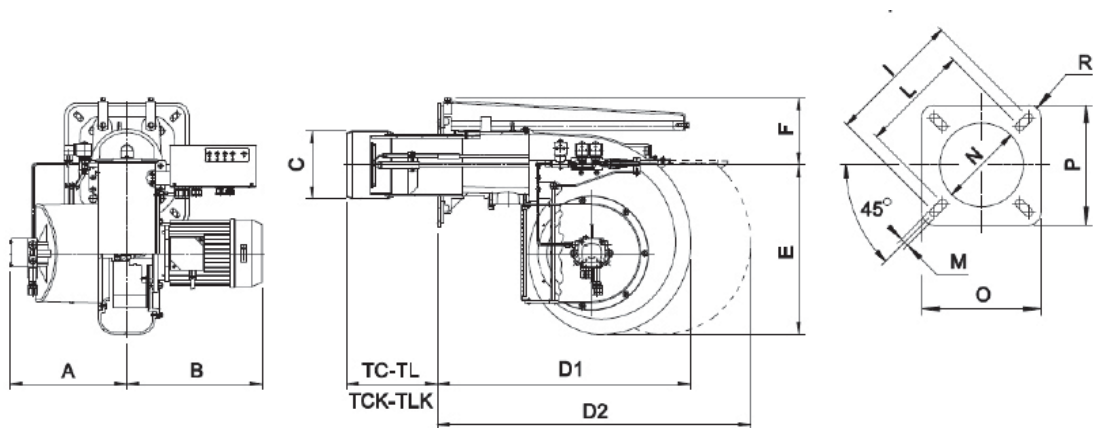

МОДЕЛЬ MODEL	A	B	C	D1	D2	E	F	TC	TCK	TLK	TL	I	L	M	N	O	P	R
FGP 50/2	188	324	150	493	-	327	100	250	-	-	335	226	205	M10	160	220	220	R30
FGP 70/2	250	310	165	660	1060	327	171	170	250	-	335	368	340	M12	180	320	320	R20
FGP 100/2	300	350	175	670	1170	438	173	200	235	370	435	368	340	M12	190	320	320	R20
FGP 120/2	350	380	212	820	1400	438	213	200	-	-	400	368	340	M14	230	320	320	R30
FGP 150/2	350	380	212	820	1400	438	213	200	-	-	400	368	340	M14	230	320	320	R30



ПРОГРЕССИВНЫЕ И МОДУЛИРУЮЩИЕ  
PROGRESSIVE & MODULATING

	kg/h		kW		3F
	min	max	min	max	
FGP 50/M	20	50	237	592	
FGP 70/M	35	70	406	812	
FGP 100/M	40	100	464	1160	
FGP 120/M	60	120	696	1392	
FGP 150/M	75	150	870	1740	

ТЕПЛОВОЙ РАСХОД / РАЗМЕРЫ (мм) - FIRING RATES / OVERALL DIMENSIONS (mm)

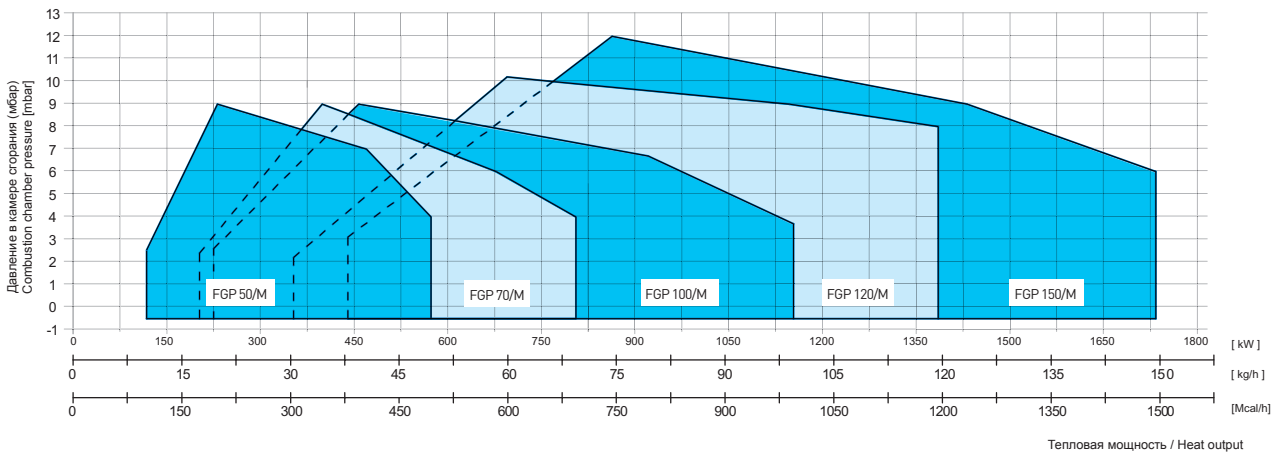
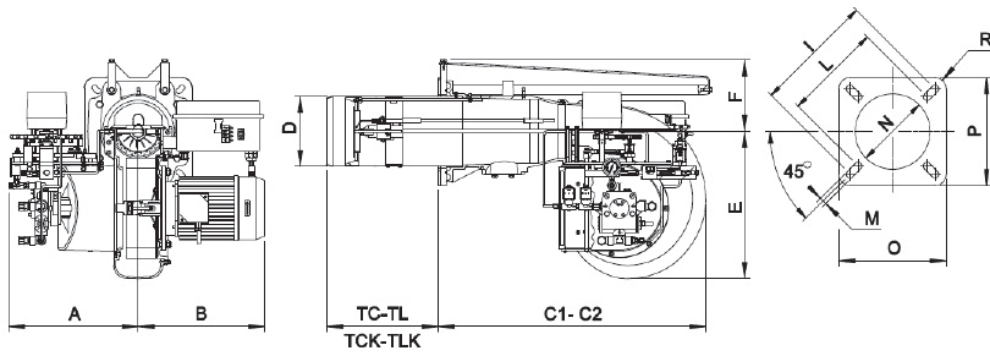

МОДЕЛЬ MODEL	A	B	C1	C2	D	E	F	I	L	M	N	O	P	R	TC	TCK	TL	TLK
FGP 50/M	350	305	530	-	150	327	145	226	205	M10	160	220	220	R30	250	-	335	-
FGP 70/M	350	310	700	1140	165	327	171	368	340	M12	180	320	320	R20	-	250	335	-
FGP 100/M	386	375	651	1150	175	438	173	368	340	M12	190	320	320	R20	-	235	-	370
FGP 120/M	386	376	815	1395	209	438	213	368	340	M14	230	320	320	R20	200	-	400	-
FGP 150/M	386	397	815	1395	209	438	213	368	340	M14	230	320	320	R20	200	-	400	-

# СЕРИЯ FGP

ТРЕХСТУПЕНЧАТЫЕ - ПРОГРЕССИВНЫЕ И МОДУЛИРУЮЩИЕ ОТ 700 ДО 11628 кВт  
3 Stages - Progressive and modulating from 700 up to 11628 kW



ТРЕХСТУПЕНЧАТЫЕ 3 STAGES	ПРОГРЕССИВНЫЕ И МОДУЛИРУЮЩИЕ PROGRESSIVE & MODULATING	kg/h		kW		⚡
		min	max	min	max	
FGP 190/3	FGP 190/M *	60	206	700	2390	3F
FGP 250/3	FGP 250/M *	80	250	930	2900	
FGP 350/3	FGP 350/M *	140	350	1620	4060	
FGP 450/3	FGP 450/M *	160	450	1850	5220	
	FGP 550/M *	200	550	2320	6380	
	FGP 650/M *	300	650	3488	7558	
	FGP 750/M *	350	750	4070	8721	
	FGP 1000/M *	345	1000	4000	11628	

\* Поставляются также версии с ИНВЕРТОРОМ и ЭЛЕКТРОННЫМ КУЛАЧКОМ

\* Available also versions with INVERTER and ELECTRONIC BURNER CONTROL

## ТЕПЛОВЫЙ РАСХОД / РАЗМЕРЫ (мм) - FIRING RATES / OVERALL DIMENSIONS (mm)

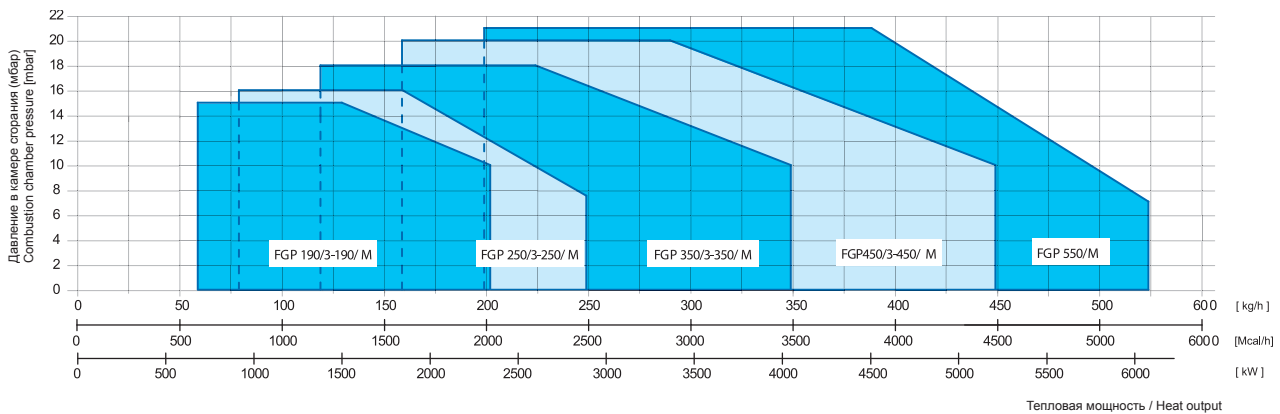
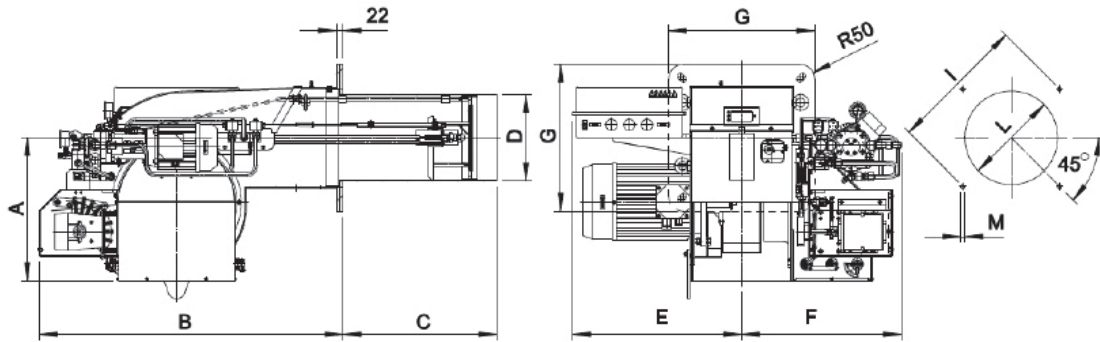

МОДЕЛЬ MODEL	* советовав/Suggested													
	A	B	C	D	E	F	G	I min	I *	I max	L min	L *	L max	M
FGP 190/3	453	835	495	234	429	429	360	396	424	438	245	280	320	M14
FGP 250/3	453	835	500	271	429	460	360	396	424	438	280	280	320	M14
FGP 350/3	481	942	535	334	507	517	490	552	552	580	350	350	450	M14
FGP 450/3	481	942	560	380	537	517	490	552	552	580	390	390	450	M14
FGP 190/M	453	920	495	234	430	530	360	396	424	438	245	280	320	M14
FGP 250/M	453	920	500	271	430	530	360	396	424	438	280	280	320	M14
FGP 350/M	481	1025	535	334	571	540	490	552	552	580	350	350	450	M14
FGP 450/M	481	1025	560	380	571	540	490	552	552	580	390	390	450	M14
FGP 550/M	481	1025	560	380	661	540	490	552	552	580	390	410	450	M14