

**ZANI SPA**

Catalogue 2010



# ZANI

Reliability, quality and durability are Zani's primary objectives.

Forty years of experience and constant training guarantee the high technical level of our designers.

Our highly qualified staff are involved in constant research into all types of treatment necessary for food use and to protect against corrosion.

This is why Zani products can boast a long working life.

One watchword has guided our work for decades: quality.

ZANI SPA V.le del Lavoro, 18  
I 45100 Rovigo  
Tel +39 0425 474815  
Fax +39 0425 474319  
zani@zani.it



# TREATMENTS

## STAINLESS STEEL

The generic causes of corrosion are negligible in the case of boilers made from stainless steel. In certain conditions however, the presence of chlorides may lead to pitting of the stainless steel. To prevent this, our boilers are made from special austenitic steels such as AISI 316 L low carbon steel, or in the case of highly corrosive water, AISI 316 Ti titanium steel.



AISI 316 L 1.4404 EN 10088-2, suitable for drinking water in compliance with Italian Ministerial Decree no. 174/2004.

## VITRIFICATION

The best guarantee against corrosion is offered by vitreous enamel (vitrification). Fired in large furnaces at more than 800°C, the enamel differs from paint in its strictly inorganic carbon free chemical composition and chemical type bond. Due to problems associated with size, it can only be applied to medium capacity cylinders.

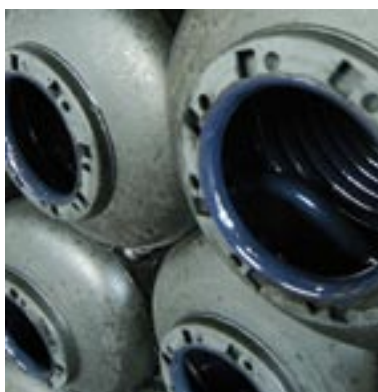

DIN 4753.3 inorganic enamelling, suitable for drinking water in compliance with Italian Ministerial Decree no. 174/2004.

## GALVANISING

Hot galvanising is performed by dipping the cylinder in a bath of molten zinc at a temperature of about 450°C. Galvanising offers double protection - PASSIVE due to the barrier effect of the surface layer of Zn and ACTIVE exploiting the so-called galvanic protection effect.



UNI EN ISO 1461 hot galvanising, suitable for drinking water in compliance with Italian Ministerial Decree no. 174/2004. .

# GUARANTEES

THE GUARANTEES in this catalogue are offered under the terms indicated in the product itself and are valid EXCLUSIVELY AGAINST PITTING caused by electrochemical corrosion. They cover duly treated and/or protected surfaces only and in particular, surfaces in contact with domestic hot water. The guarantees are invalidated in the following cases:

- a) If the product is not equipped with the efficient permanent cathodic protection normally provided.
- b) If the quality requisites of the drinking water do not comply with Italian Legislative Decree no. 31/01 (implementing 98/83/EC) and in particular, if the parameters listed below are not respected:
- c) If whenever a heat exchanger is dismantled for cleaning or maintenance, it is not reassembled in scrupulous respect of INSULATION and SHORT CIRCUITING conditions, in accordance with the precise instructions given in the manuals accompanying all appliances.
- d) If the maximum operating temperature indicated for the specific water heater is not respected. It should be borne in mind that water becomes noticeably more corrosive as the temperature increases, particularly above 60°C.

PARAMETER	HYDROGENIONIC CONCENTRATION pH(*)	ELECTRICAL CONDUCTIVITY $\mu\text{S cm}^{-1}$ (a 20°C)	CHLORIDES mg/l Cl	SULPHATES mg/l SO <sub>4</sub>	TOTAL HARDNESS °Fr (*)
PARAMETRIC VALUE	6,5÷9,5	2500	250	250	Minimum required 15

(\*) As well as satisfying the hygiene requirements, the water must be treated to achieve equilibrium (neither scale forming nor corrosive) according to the TILLMANN diagram (UNI 9182 Art.17). The specified treatments (UNI 8065) must not, however, prevent its use for human consumption and they must be applied using appropriate equipment. In the case of softening or desalination, total water hardness must not be less than 15°Fr (Italian Ministerial Decree no. 443/90).

The guarantees are also regulated by the general terms and conditions of sale contained in this catalogue.

# PROTECTION DEVICES

## OVERPRESSURE PROTECTION

**Safety valve:** As water cannot be compressed and increases in volume when heated, an adequate expansion system must be provided to prevent possible damage to the water heater.

It is recommended that ISPESL (Istituto Superiore per la Prevenzione e la Sicurezza del Lavoro, Italian Higher Institute for Prevention and Safety at Work) standards (Raccolta R-Cap. R.1.A) are adopted. In the case of devices for heating drinking water, these standards specify that the expansion system may be constructed using a counterweight or spring vent valve with a diameter calculated as follows:

$$d \geq \sqrt{\frac{V}{5}}$$

V = volume of water heater in litres.  
d = diameter of valve opening with a minimum of 15 mm.

N.B. The valve setting pressure must not exceed the maximum operating pressure of the water heater.

**Expansion tank:** To prevent frequent activation of the safety valve and dangerous stresses on the water heater, a closed expansion tank with non-toxic membrane for food use must also be fitted.

**Water hammer:** Sudden or instantaneous interruption of the water flow may produce PRESSURE WAVES capable of causing serious damage and/or breakage. All hot and cold water distribution systems must therefore include devices to mitigate water hammer. These may take the form of mechanical spring devices or preferably hydropneumatic devices with a permanent or rechargeable air cushion (UNI 9182 Art. 15).

**Frost protection:** If tanks are exposed to temperatures below 0°C for long periods, they should be protected by heating elements, or a continuous flow must be maintained to prevent water stagnation (UNI 9182 Art.20.4.3).

## ELECTRICAL PROTECTION

To protect the user against currents resulting from malfunctions, CONNECT the electrical earths and extraneous conducting parts CORRECTLY(as specified in Law no. 46/90).

## CATHODIC PROTECTION AGAINST CORROSION

CORROSION is a natural electrochemical phenomenon affecting water heaters in particular as they contain constantly renewed water which becomes noticeably more corrosive as the temperature increases (particularly above 60°C). CATHODIC PROTECTION is based on the principle that corrosion of a structure is limited to the ANODE ZONES, while it never occurs in the CATHODE ZONES.

### MAGNESIUM ANODES

To ensure cathodic protection of even the smallest inevitable IMPERFECTIONS IN THE TREATMENT of the inside of our water heaters, they are fitted with sacrificial MAGNESIUM ANODES which generate a very small current as they are consumed, effectively protecting the structure from corrosion.

Our ANODES are made from special AZ 63 type magnesium alloy which guarantees PHYSIOLOGICAL INNOCUOUSNESS, ELECTRODE POTENTIAL ( $\leq -0.9V$ ) and MASS LOSS RATE ( $\leq 30 \text{ g} \cdot \text{m}^{-2} \cdot \text{d}^{-1}$ ) in compliance with DIN 4753-6.

### ELECTRONIC IMPRESSED CURRENT ANODE CORREX

Permanent cathodic protection can be obtained by using an electronic impressed current anode. As they are not subject to wear, the CORREX is particularly suitable for protecting ZANI storage water heaters, accumulators and boilers (even if already installed) operating with water in particularly chemically and physically corrosive conditions.

An electrical socket must be available near the boiler, verifying that, in the event of interruptions, the electricity supply is restored and maintained.

The wires supplied must not be tampered with or modified.

The product is accompanied by a manual.



CORREX® is a registered trade mark of Hydro Magnesium



# REGULATIONS, STANDARDS AND PRECAUTIONS

Information and recommendations for correct interpretation and application of **Law no. 46/90, art. 7 "GOOD WORKMANSHIP"**.

## HOT WATER STORAGE

(DPR 412/93 Art. 5.7) ...heat generators for the centralised production of hot water for hygiene and sanitary purposes for multiple residential type uses must be dimensioned according to UNI 9182 technical standards, they must be fitted with a hot water storage system with an appropriate capacity...

## WATER SUPPLY

The quality requisites of the drinking water feeding the boiler must comply with Legislative Decree no. 31/01, implementing directive 98/83 EC. Our catalogue gives a number of guide values (page 3).

## TANKS

Facilities for the storage of fuel oil or diesel for HEATING INSTALLATIONS must comply with the standards specified in the Italian Ministry of the Interior circular of 28-04-05.

## WATER HAMMER

Possible WATER HAMMER resulting from sudden or instantaneous interruption of the water flow may produce PRESSURE WAVES capable of causing serious damage and/or breakage (UNI 9182 Art. 15)... all hot and cold water distribution systems must therefore include devices to mitigate water hammer. These may take the form of mechanical spring devices or preferably hydropneumatic devices with a permanent or rechargeable air cushion...

## DIMENSIONING THE STORAGE TANK

(UNI 9182 Art. 9.3.1) the storage tank must be dimensioned in relation to the total water demand during the peak period, the length of the pre-heating period and the temperature of the cold water, the hot water distributed and the water stored.

## SEPARATE GENERATORS

(DPR 412/93 Art. 5.6) ...the centralised heat energy required for winter heating of the rooms and the production of hot water for hygiene and sanitary purposes for multiple residential type uses must be produced with separate heat generators...

## EARTH INSTALLATION

(L. 46/90 Art. 7.2) ...in particular, electrical installations must be fitted with earth systems and differential switches or equivalent protection devices...

## LEGIONNAIRES' DISEASE

To eliminate the danger of the presence of this bacteria, the recommendations of the World Health Organisation (WHO Bulletin OMS, Vol. 681990) are given below:

- Heat the water to a storage temperature of 60°C.
- Make sure the temperature of the water in all parts of the installation is at least 50°C.

## CATHODIC PROTECTION

Our ANODES are made from special AZ 63 type magnesium alloy which guarantees PHYSIOLOGICAL INNOCUOUSNESS, ELECTRODE POTENTIAL and MASS LOSS RATE in compliance with DIN 4753-6.

## FROST PROTECTION

As water increases in volume when it freezes and the pressure building up inside a closed tank may be sufficient to cause breakage, the installation must be designed and operates so as to ensure the water never drops below 0°C.

## RECIRCULATION

(UNI 9182 Art. 9.5)... in centralised distribution installations, it is indispensable to include a recirculation system allowing the water to remain in constant movement, thus avoiding the consequences of heat loss caused by stagnation.

## DISTRIBUTION TEMPERATURE

(DPR 412/93 Art. 5.7) ...heat generators intended to produce centralised hot water for hygiene and sanitary purposes for a number of residential type uses... must be designed and operated so that the water temperature measured at the point of entry into the distribution system does not exceed 48°C with a tolerance of +5°C.

## STORAGE TEMPERATURE

(UNI 9182 - Appendix L) Even though the standard specifies storage temperatures of up to 65°C, temperatures of no more than 60°C are recommended in order to save energy and limit scale precipitation and electrochemical corrosion. The capacity of the boiler must be suitably dimensioned so as to avoid exceeding this temperature. In addition (Appendix U), water at a temperature of more than 60°C must not be conveyed through galvanised steel pipes.

## WATER TREATMENTS

As well as satisfying the hygiene requirements, the water must be treated to achieve equilibrium (neither scale forming nor corrosive) according to the TILLMANN diagram (UNI 9182 Art.17). The specified treatments (UNI 8065) must not, however, prevent its use for human consumption and they must be applied using appropriate equipment. In the case of softening or desalination, total water hardness must not be less than 15°Fr (Italian Ministerial Decree no. 443/90).

## SAFETY VALVE

(ISPESL - RACCOLTA R -Cap. R. 1.A) ...in the case of appliances to heat water intended for human consumption, the expansion system to protect the recipient should be constructed using a counterweight or spring air vent **with a diameter in mm of not less than  $\sqrt{V \cdot 5^{-1}}$** , where V is the volume in litres of the water heater, with a minimum of 15 mm. The valve must be calibrated to a pressure no higher than the maximum operating pressure of the heater.

## EXPANSION TANK

As water cannot be compressed and increases in volume when heated, to prevent frequent activation of the safety valve and dangerous stresses to the water heater, a closed expansion tank with a membrane suitable for food use and an appropriate capacity must also be fitted. It must have a preload pressure equal to that of the water pressure upstream of the water heater. It is recommended that the expansion tank has a capacity no less than 10% that of the water heater.

## STEAM AND SUPERHEATED WATER

Boilers with heat exchangers fed by steam or superheated water are also subject to the safety regulations as specified in DM 1-12-75 (ISPESL - Raccolta R - Cap. R. 3.E. ).

# BVS-P

Water Heater

80 °C 8 bar

Art. 3.3 Dir. 97/23/EC

**SmaltoPLAST® WATER HEATER**  
**REMOVABLE HEAT EXCHANGER**  
**RIGID INSULATION**



### Use

Production and storage of domestic hot water (DHW).  
 Working temperature: max 80°C  
 Working pressure: max. 8 bar.

### Anti-corrosion treatment

**SmaltoPLAST®** : treatment suitable for drinking water; RAL 7038 grey colour

### Heat exchanger

"U" tube bundle expanded into tube sheet, suitable for drinking water.  
 -DHP copper tubes (99.9%).  
 -AISI 316 L stainless steel tubes.  
 Working temperature: max. 110°C  
 Working pressure: max. 12 bar

### Gaskets

Dielectric EPDM rubber for food use code GGE.

### Insulation

-VERTICAL VERSION:  
 Rigid polyurethane, 30 mm thick (PUR 30), complies with DPR 412/93  
 - HORIZONTAL VERSION:  
 Flexible polyurethane, 50 mm thick (PUF 50).

### External covering

Synthetic leather (SCAI) RAL 7038 grey colour

### Cathodic protection

Magnesium anodes (AMS) in AZ 63 alloy with welded cap.

### Anti-corrosion guarantee

3 years.

ACCESSORIES ON REQUEST Page 40

CORREX: impressed current anode for PERMANENT CATHODIC PROTECTION.

### HEAT UP TIME(1) 1 HOUR

LITRES	COPPER		STAINLESS STEEL		OUTPUT kW	DHW PRODUCTION (2)			Δp(3) m H <sub>2</sub> O	WEIGHT kg
	CODE	EURO	CODE	EURO		l/h	l/10'	l/60'		
200	BVSR 0200 P		BVSX 0200 P		12	300	278	528	0,3	60
300	BVSR 0300 P		BVSX 0300 P		18	450	418	793	0,5	70
500	BVSR 0500 P		BVSX 0500 P		24	600	671	1171	0,7	105
750	BVSR 0750 P		BVSX 0750 P		36	900	1007	1757	1,8	130
1000	BVSR 1000 P		BVSX 1000 P		48	1200	1343	2343	2,6	170
1500	BVSR 1500 P		BVSX 1500 P		73	1800	2014	3514	4,5	250
2000	BVSR 2000 P		BVSX 2000 P		97	2400	2686	4686	6,3	295

HORIZONTAL version up to 1000 l (code BOSR, BOSX): 30% INCREASE and only flexible insulation (PUF 50)

HORIZONTAL VERSION superior to 1000 l: see page 7

(1) Nominal time required to heat the domestic hot water 10-60°C.

(2) Production of DHW 10-45°C with primary 80-70°C and storage at 60°C: continuous (l/h); peak in first 10 mins (l/10'); peak in first hour (l/60').

(3) Heat exchanger pressure drop.

LITRES	DIMENSIONS mm														FITTINGS		ANODES TYPE
	A	B	B1	C	C1	De	Di	E	F	H	H1	L	M	N	e1-u1	e2-u2	
200	295	320	230	450	360	520	450	1195	300	1380	620	1400	330	185	1" 1/4	1" 1/4	AMS 1
300	325	350	225	480	355	620	550	1215	300	1410	715	1450	350	205	1" 1/4	1" 1/4	AMS 1
500	345	370	235	500	365	720	650	1485	300	1710	825	1760	385	240	1" 1/4	1" 1/4	AMS 4
750	370	395	220	525	350	820	750	1610	300	1855	910	1900	405	260	1" 1/4	1" 1/2	AMS 4
1000	375	438	218	562	342	870	800	1915	300	2170	955	2205	420	270	1" 1/4	1" 1/2	AMS 4
1500	435	484	--	666	--	1020	--	2055	380	2400	--	--	--	--	1" 1/2	2"	AMS 4
2000	450	500	--	682	--	1170	--	2070	380	2450	--	--	--	--	1" 1/2	2"	AMS 4

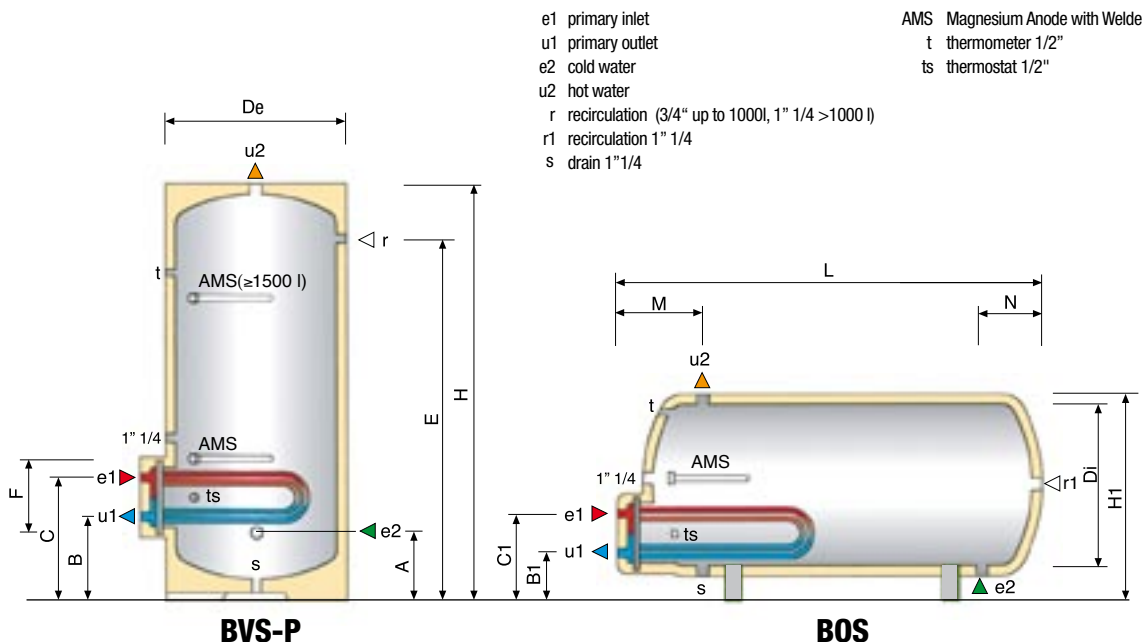



# SmaltoPLAST® WATER HEATER REMOVABLE HEAT EXCHANGER FLEXIBLE INSULATION

Water Heater

**80 °C 6 bar**

Art. 3.3 Dir. 97/23/EC

# BVS

### HEAT UP TIME (1) 1 HOUR

LITRES	COPPER		STAINLESS STEEL		OUTPUT kW	DHW PRODUCTION (2)			Δp(3) mH <sub>2</sub> O	WEIGHT kg
	CODE	EURO	CODE	EURO		l/h	l/10'	l/60'		
1500	BVSR 1500		BVSX 1500		73	1800	2014	3514	4,5	230
2000	BVSR 2000		BVSX 2000		97	2400	2686	4686	6,3	270
2500	BVSR 2500		BVSX 2500		122	3000	3357	5857	8,3	306
3000	BVSR 3000		BVSX 3000		146	3600	4029	7029	9,9	345
4000	BVSR 4000		BVSX 4000		195	4800	5371	9371	5,5	470
5000	BVSR 5000		BVSX 5000		244	6000	6714	11724	9,3	550

**HORIZONTAL VERSION (code BOSR, BOSX): 30% increase**

(1) Nominal time required to heat the domestic hot water 10÷60°C.

(2) Production of DHW 10÷45°C with primary 80÷70°C and storage at 60°C: continuous (l/h); peak in first 10 mins (l/10'); peak in first hour (l/60').

(3) Heat exchanger pressure drop.

### Use

Production and storage of domestic hot water (DHW).

Working temperature: max 80°C

Working pressure: max. 6 bar.

### Anti-corrosion treatment

**SmaltoPLAST®**: treatment suitable for drinking water; RAL 7038 grey colour.

### Heat exchanger

"U" tube bundle expanded into tube sheet, suitable for drinking water.

-DHP copper tubes (99.9%).

-AISI 316 L stainless steel tubes.

Working temperature: max. 110°C

Working pressure: max. 12 bar

### Gaskets

Dielectric EPDM rubber for food use code GGE.

### Insulation

Flexible polyurethane, 50 mm thick (PUF 50).

### External covering

Synthetic leather (SCAI) RAL 7038 grey colour

### Cathodic protection

Magnesium anodes (AMS) in AZ 63 alloy with welded cap.

### Anti-corrosion guarantee

3 years.

LITRES	DIMENSIONS mm													FITTINGS		ANODES TYPE
	A	B	B1	C	C1	Di	E	F	H	H1	L	M	N	e1-u1	e2-u2	
1500	435	484	274	666	456	950	2055	380	2400	1155	2380	465	315	1" 1/2	2"	AMS 4
2000	450	500	254	682	436	1100	2070	380	2450	1285	2450	500	350	1" 1/2	2"	AMS 4
2500	510	560	244	742	426	1200	2180	380	2540	1375	2560	530	380	1" 1/2	2"	AMS 4
3000	520	570	229	752	411	1300	2140	380	2550	1460	2600	550	400	1" 1/2	2"	AMS 8
4000	570	625	295	845	515	1400	2440	430	2870	1565	2910	625	440	2"	2" 1/2	AMS 8
5000	580	635	330	855	550	1600	2450	430	2920	1780	2970	655	470	2"	2" 1/2	AMS 8

ACCESSORIES ON REQUEST Page 40

CORREX: impressed current anode for PERMANENT CATHODIC PROTECTION.

- e1 primary inlet
- u1 primary outlet
- e2 cold water
- u2 hot water
- r recirculation 1" 1/4
- s drain (1" 1/4 up to 2000 l, 2" >2000 l)
- s1 drain 1" 1/4

- AMS Magnesium Anode Welded cap
- S exchanger Support (≥4000 l)
- t thermometer 1/2"
- ts thermostat 1/2"

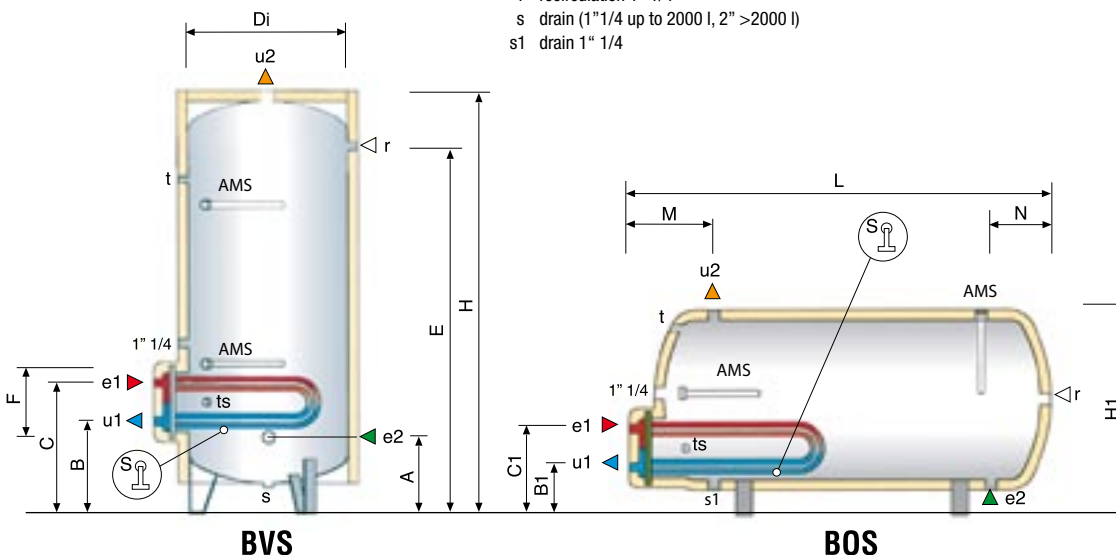

**Use**

Production and storage of domestic hot water (DHW).  
Working temperature: max 80°C  
Working pressure: max. 8 bar.

**Material**

AISI 316 L stainless steel suitable for drinking water.

**Heat exchanger**

"U" tube bundle expanded into tube sheet, suitable for drinking water.  
-AISI 316 L stainless steel tubes and plate.  
Working temperature: max. 110°C  
Working pressure: max. 12 bar

**Gaskets**

Dielectric EPDM rubber for food use code GGE.

**Insulation**

- Up to 1000 l.:  
Rigid polyurethane, 30 mm thick (PUR 30), complies with DPR 412/93  
- Superior to 1000 l.:  
Flexible polyurethane, 50 mm thick (PUF 50).

**External covering**

Synthetic leather (SCAI) RAL 7038 grey colour

**Anti-corrosion guarantee**

3 years.

**HEAT UP TIME (1) 1 HOUR**

LITRES	CODE	EURO*	OUTPUT kW	DHW PRODUCTION (2)			Δp(3) m H <sub>2</sub> O	WEIGHT kg
				l/h	l/10'	l/60'		
300	BVXX 0300 P		18	450	418	793	0,5	65
500	BVXX 0500 P		24	600	671	1171	0,7	95
750	BVXX 0750 P		36	900	1007	1757	1,8	125
1000	BVXX 1000 P		48	1200	1343	2343	2,6	135
1500	BVXX 1500		73	1800	2014	3514	4,5	215
2000	BVXX 2000		97	2400	2686	4686	6,3	250
2500	BVXX 2500		122	3000	3357	5857	8,3	290
3000	BVXX 3000		146	3600	4029	7029	9,9	320
4000	BVXX 4000		195	4800	5371	9371	5,5	460
5000	BVXX 5000		244	6000	6714	11714	9,3	550

\* Prices subject to order confirmation

(1) Nominal time required to heat the domestic hot water 10÷60°C.

(2) Production of DHW 10÷45°C with primary 80÷70°C and storage at 60°C: continuous (l/h); peak in first 10 mins (l/10'); peak in first hour (l/60').

(3) Heat exchanger pressure drop.

LITRES	DIMENSIONS mm								FITTINGS	
	A	B	C	De	Di	E	F	H	e1-u1	e2-u2
300	300	330	452	620	-	1190	300	1410	1"1/4	1"1/4
500	325	355	477	720	-	1465	300	1710	1"1/4	1"1/4
750	405	438	562	870	-	1545	300	1900	1"1/4	1"1/2
1000	405	438	562	870	-	1795	300	2150	1"1/4	1"1/2
1500	435	500	650	-	950	2055	380	2400	1"1/2	2"
2000	450	515	665	-	1100	2070	380	2450	1"1/2	2"
2500	510	575	725	-	1250	2130	380	2550	1"1/2	2"
3000	510	575	725	-	1250	2380	380	2800	1"1/2	2"
4000	570	635	785	-	1400	2440	380	2870	1"1/2	2"1/2
5000	580	645	795	-	1600	2450	380	2920	1"1/2	2"1/2

- e1 primary inlet
- u1 primary outlet
- e2 cold water
- u2 hot water
- r recirculation (3/4" up to 1000l, 1" 1/4 >1000 l)
- s drain (1"1/4 up to 2000 l, 2" >2000 l)
- s exchanger Support (≥4000 l)
- t thermometer 1/2"
- ts thermostat 1/2"

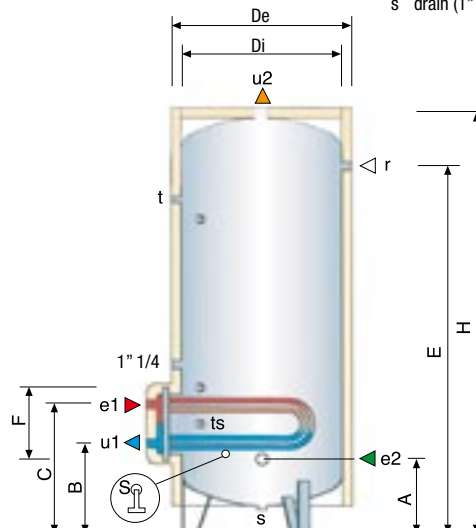



**Use**

Rapid production and storage of domestic hot water (DHW).  
Working temperature : 90°C max  
Working pressure: 8 bars max.

**Anti-corrosion treatment**

VITRIFICATION: VITREOUS ENAMEL suitable for drinking water.

**Heat exchanger**

Spiral wound carbon steel tube welded to tank.  
Working temperature: 110°C max.  
Working pressure: 12 bars max.

**Insulation**

Rigid polyurethane, 30 mm thick (PUR 30), complies with DPR 412/93

**External covering**

Synthetic leather (SCAI) RAL 7038 grey.

**Cathodic protection**

Magnesium anodes (AMS) in AZ 63 alloy with welded cap.

**Anti-corrosion guarantee**

5 years.

LITRES	CODE	EURO	EXCHANGER			PRE-HEATING (1) min	DHW PRODUCTION (2)			Δp(3) mH <sub>2</sub> O	WEIGHT kg
			kW	m <sup>2</sup>	l		l/h	l/10'	l/60'		
150	BRV 0150		23	0,75	5	28	565	287	758	0,4	55
200	BRV 0200		23	0,75	5	37	565	351	822	0,4	60
300	BRV 0300		34	1,1	7	37	835	524	1221	1,1	75
500	BRV 0500		47	1,5	10	45	1154	835	1797	2,6	125
750	BRVF 0750		61	2	15	52	1498	1214	2463	1,8	160
1000	BRVF 1000		73	2,4	19	57	1793	1584	3079	2,6	195

(1) Nominal time required to heat the domestic hot water 10=60°C.

(2) Production of DHW 10=45°C with primary 80=70°C and storage at 60°C: continuous (l/h); peak in first 10 mins (l/10'); peak in first hour (l/60').

(3) Heat exchanger pressure drop.

ACCESSORIES ON REQUEST Page 40

CORREX: impressed current anode for PERMANENT CATHODIC PROTECTION

LITRES	DIMENSIONS mm						CONNECTIONS			ANODE TYPE
	A	B	C	De	E	H	e1-u1	e2	u2	
150	200	295	660	520	890	1095	1"	1"	1 1/4"	AMS 5
200	200	295	660	520	910	1295	1"	1"	1 1/4"	AMS 5
300	215	290	730	620	960	1340	1"	1"	1 1/4"	AMS 5
500	250	335	885	720	1195	1615	1"	1 1/4"	1 1/4"	AMS 5
750	280	380	965	820	1280	1795	1 1/4"	1 1/2"	1 1/2"	AMS 1
1000	290	390	1090	870	1410	2105	1 1/4"	1 1/2"	1 1/2"	AMS 1

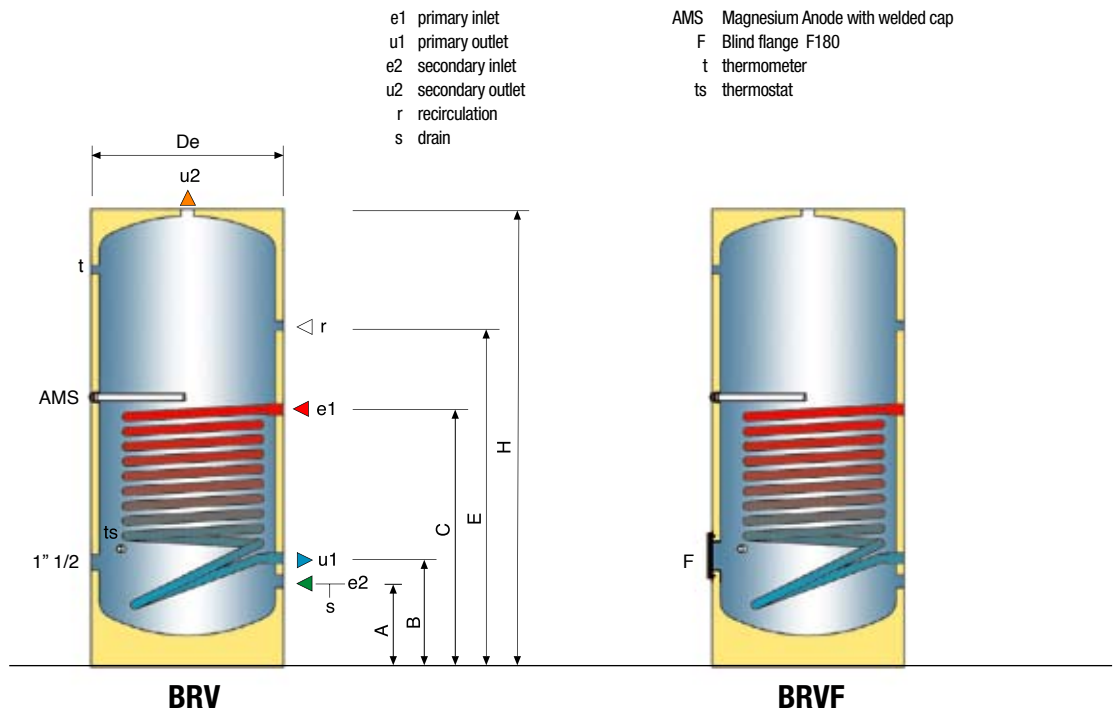

# ACS-P

Storage tank **80 °C 8 bar**  
Art. 3.3 Dir. 97/23/EC

**SmaltoPLAST® STORAGE TANKS**  
**DOMESTIC HOT WATER**  
**RIGID INSULATION**



### Use

Storage of domestic hot water (DHW).  
Working temperature: max 80°C  
Working pressure: max. 8 bar.

### Anti-corrosion treatment

SmaltoPLAST® : treatment suitable for drinking water; RAL 7038 grey colour

### Insulation

Rigid polyurethane, 30 mm thick (PUR 30), complies with DPR 412/93

### External covering

Synthetic leather (SCAI) RAL 7038 grey colour

### Cathodic protection

Magnesium anodes (AMS) in AZ 63 alloy with welded cap.

### Anti-corrosion guarantee

3 years.

LITRES	CODE	EURO	DIMENSIONS mm								FITTINGS ac-af	ANODES TYPE	WEIGHT kg
			A	B	C	De	H	H1	L	N			
200	ACS 0200 P		275	665	1165	520	1380	655	1270	185	1" 1/4	AMS 1	40
300	ACS 0300 P		295	685	1185	620	1410	755	1320	205	1" 1/4	AMS 1	50
500	ACS 0500 P		325	715	1465	720	1710	850	1600	240	1" 1/4	AMS 4	85
750	ACS 0750 P		345	835	1585	820	1855	945	1740	260	1" 1/2	AMS 4	110
1000	ACS 1000 P		355	895	1895	870	2170	990	2060	270	1" 1/2	AMS 4	135
1500	ACS 1500 P		435	955	2055	1020	2400	1155	2285	320	2"	AMS 4	210
2000	ACS 2000 P		450	1040	2070	1170	2450	1285	2355	350	2"	AMS 4	250

HORIZONTAL VERSION (code ACSO-P): 30% increase

## ACSF-P

With inspection flange (not suitable for exchanger installation)

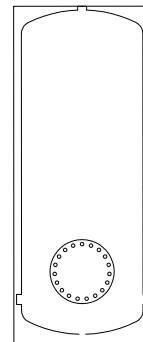

øF=300 200÷1000 litres  
øF=380 1500÷5000 litres

ACCESSORIES ON REQUEST Page 40

CORREX: impressed current anode for PERMANENT CATHODIC PROTECTION.

ac hot water  
af cold water  
ep external heat exchanger inlet 1" 1/4  
up external heat exchanger outlet 1" 1/4  
r recirculation (3/4" up to 1000l, 1" 1/4 >1000 l)  
s drain 1" 1/4  
AMS Magnesium Anode with Welded cap  
t thermometer 1/2"  
ts thermostat 1/2"

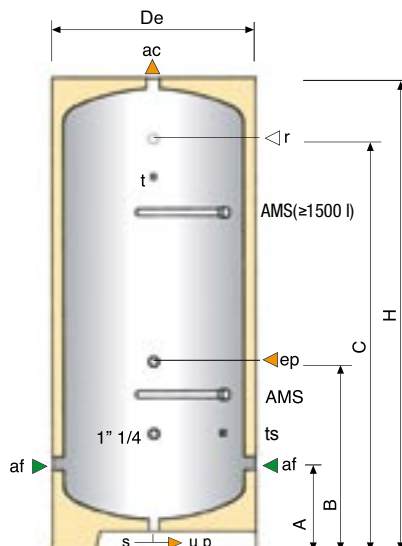

**ACS-P**

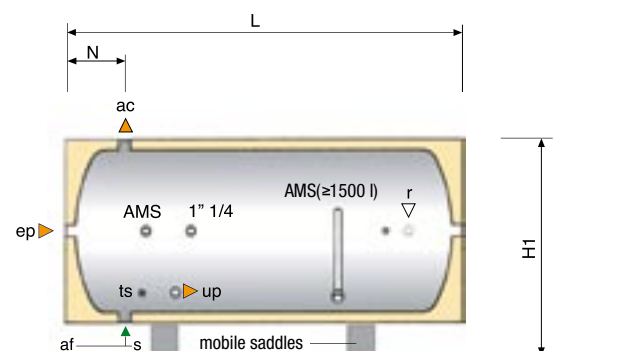

**ACSO-P**



**SmaltoPLAST® STORAGE TANKS**  
**DOMESTIC HOT WATER**  
**FLEXIBLE INSULATION**

Storage tank

**80 °C 6 bar**

Art. 3.3 Dir. 97/23/EC

**ACS**

LITRES	CODE	EURO	DIMENSIONS mm								FITTINGS ac-af	ANODES TYPE	WEIGHT kg
			A	B	C	Di	H	H1	L	N			
1500	ACS 1500		435	955	2055	950	2400	1155	2285	315	2"	AMS 4	200
2000	ACS 2000		450	1040	2070	1100	2450	1285	2355	350	2"	AMS 4	235
2500	ACS 2500		510	1100	2180	1200	2540	1375	2410	380	2"	AMS 4	270
3000	ACS 3000		520	1110	2140	1300	2550	1460	2450	400	2"	AMS 8	300
4000	ACS 4000		570	1240	2440	1400	2870	1565	2720	440	2" 1/2	AMS 8	400
5000	ACS 5000		580	1250	2450	1600	2920	1780	2780	470	2" 1/2	AMS 8	470

HORIZONTAL VERSION (code ACSO-P): 30% increase

**Use**

Storage of domestic hot water (DHW).  
 Working temperature: max 80°C  
 Working pressure: max. 6 bar.

**Anti-corrosion treatment**

SmaltoPLAST® : treatment suitable for drinking water; RAL 7038 grey colour

**Insulation**

Flexible polyurethane, 50 mm thick (PUF 50).

**External covering**

Synthetic leather (SCAI) RAL 7038 grey colour

**Cathodic protection**

Magnesium anodes (AMS) in AZ 63 alloy with welded cap.

**Anti-corrosion guarantee**

3 years.

**ACSF**

With inspection flange (not suitable for exchanger installation)

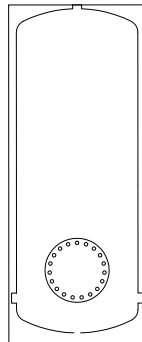

øF=300 200÷1000 litres  
 øF=380 1500÷5000 litres

- ac hot water
- af cold water
- ep external heat exchanger inlet 1" 1/4
- up external heat exchanger outlet 1" 1/4
- r recirculation (3/4" up to 1000l, 1" 1/4 >1000 l)
- r1 recirculation 1" 1/4
- s drain 1"1/4

- AMS Magnesium Anode with Welded cap
- t thermometer 1/2"
- ts thermostat 1/2"

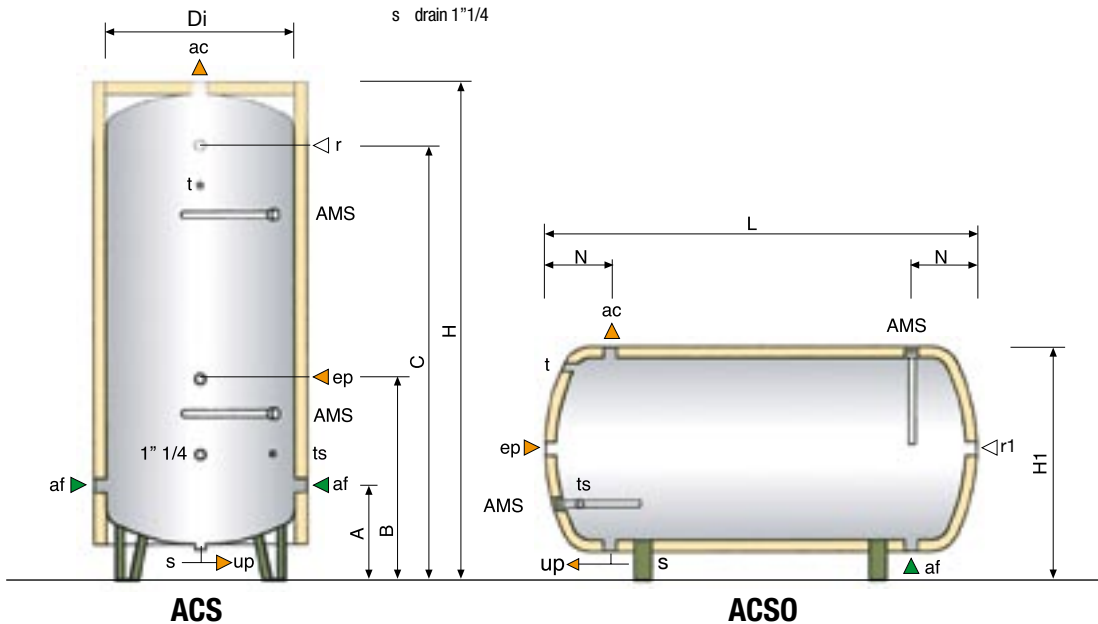

ACCESSORIES ON REQUEST Page 40

CORREX: impressed current anode for PERMANENT CATHODIC PROTECTION.



**Use**

Production and storage of domestic hot water (DHW) using solar energy, heat pumps and condensate recovery.

Working temperature: max 80°C

Working pressure: max. 6 bar.

**Anti-corrosion treatment**

**SmaltoPLAST®**: treatment suitable for drinking water; RAL 7038 grey colour.

**Heat exchanger**

"U" tube bundle expanded into tube sheet, suitable for drinking water.

-DHP copper tubes (99.9%).

-AISI 316 L stainless steel tubes.

Working temperature: max. 110°C

Working pressure: max. 12 bar

**Gaskets**

Dielectric EPDM rubber for food use code GGE.

**Insulation**

Flexible polyurethane, 50 mm thick (PUF 50).

**External covering**

Synthetic leather (SCAI) RAL 7038 grey colour

**Cathodic protection**

Magnesium anodes (AMS) in AZ 63 alloy with welded cap.

**Anti-corrosion guarantee**

5 years.

**ACCESSORIES ON REQUEST Page 40**

CORREX: impressed current anode for PERMANENT CATHODIC PROTECTION.

LITRES	COPPER		STAINLESS STEEL		HEAT EXCHANGERS						WEIGHT kg
	CODE	EURO	CODE	EURO	S1			S2			
					(1)	(2)	(3)	(1)	(2)	(3)	
300	BSR 0300		BSX 0300		48 / 1,6	32 / 0,8	16 / 0,3	-	-	-	80
500	BSR 0500		BSX 0500		72 / 3,2	48 / 1,6	24 / 0,5	-	-	-	115
750	BSR 0750		BSX 0750		96 / 0,6	64 / 0,3	32 / 0,1	-	-	-	160
1000	BSR 1000		BSX 1000		120 / 0,9	80 / 0,5	40 / 0,2	-	-	-	190
1500	BSR 1500		BSX 1500		168 / 1,9	112 / 0,9	56 / 0,3	-	-	-	260
2000	BSR 2000		BSX 2000		96 / 6,1	64 / 3,1	32 / 1,0	96 / 6,1	64 / 3,1	32 / 1,0	310
3000	BSR 3000		BSX 3000		144 / 9,8	96 / 4,9	48 / 1,5	144 / 9,8	96 / 4,9	48 / 1,5	390
4000	BSR 4000		BSX 4000		192 / 5,3	128 / 2,6	64 / 0,8	192 / 5,3	128 / 2,6	64 / 0,8	530
5000	BSR 5000		BSX 5000		240 / 9,1	160 / 4,7	80 / 1,4	240 / 9,1	160 / 4,7	80 / 1,4	620

- (1) Solar 75÷65°C and DHW 10÷45°C : power kW/pressure drop m H2O
- (2) Solar 60÷50°C and DHW 10÷40°C : power kW/pressure drop m H2O
- (3) Solar 45÷35°C and DHW 10÷30°C : power kW/pressure drop m H2O

LITRES	DIMENSIONS mm									FITTINGS		ANODES TYPE
	A	B	B1	C	C1	Di	E	F	H	es-us	e2-u2	
300	325	328	-	510	-	550	1215	380	1410	1" 1/2	1" 1/4	AMS 1
500	345	363	-	545	-	650	1485	380	1710	1" 1/2	1" 1/4	AMS 4
750	370	420	-	640	-	750	1610	430	1855	2"	1" 1/2	AMS 4
1000	375	425	-	645	-	800	1915	430	2170	2"	1" 1/2	AMS 4
1500	435	465	-	685	-	950	2055	430	2400	2"	2"	AMS 4
2000	450	500	950	682	1132	1100	2070	380	2450	1" 1/2	2"	AMS 4
3000	520	570	1010	752	1192	1300	2140	380	2550	1" 1/2	2"	AMS 8
4000	570	633	1138	838	1343	1400	2440	430	2870	2"	2" 1/2	AMS 8
5000	580	643	1148	848	1353	1600	2450	430	2920	2"	2" 1/2	AMS 8

- es solar inlet
- us solar outlet
- e2 cold water
- u2 hot water
- r recirculation (3/4" up to 1000l, 1" 1/4 >1000 l)
- s drain (1" 1/4 up to 2000 l, 2" >2000 l)

- AMS Magnesium Anode Welded cap
- S exchanger Support (≥ 4000 l)
- S1-S2 Solar Exchanger
- sd probe 1/2"
- t thermometer 1/2"

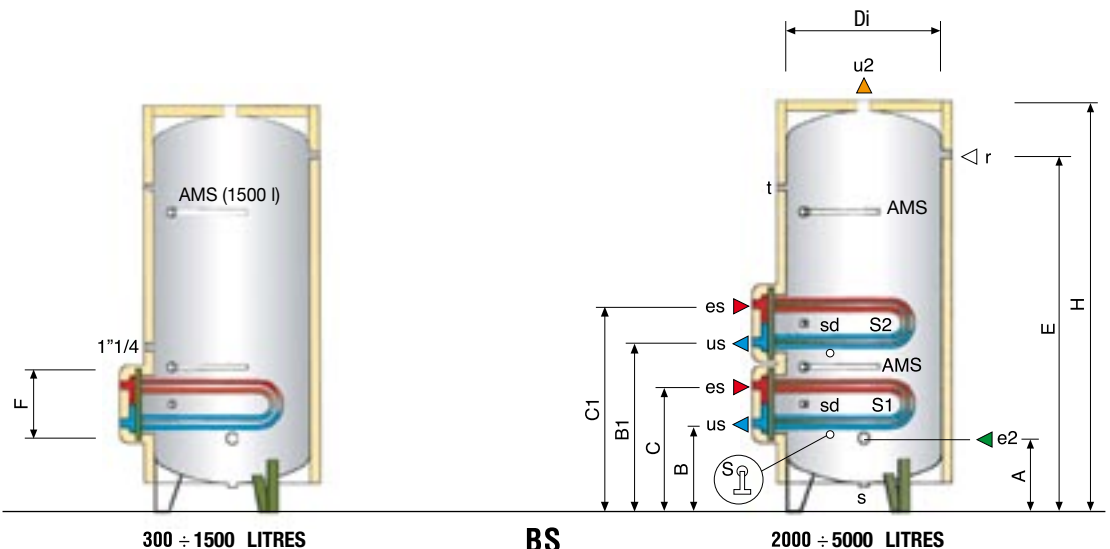





ENHANCED SOLAR WATER HEATERS  
**SmaltoPLAST®**  
 REMOVABLE HEAT EXCHANGER

Water Heater

**80 °C 6 bar**  
 Art. 3.3 Dir. 97/23/EC

BSI

LITRES	COPPER		STAINLESS STEEL		HEAT EXCHANGERS								WEIGHT kg
	CODE	EURO	CODE	EURO	S1			S2			I		
					(1)	(2)	(3)	(1)	(2)	(3)	(4)		
300	BSIR 0300		BSIX 0300		48 / 1,6	32 / 0,8	16 / 0,3	-	-	-	12 / 0,3	95	
500	BSIR 0500		BSIX 0500		72 / 3,2	48 / 1,6	24 / 0,5	-	-	-	18 / 0,5	130	
750	BSIR 0750		BSIX 0750		96 / 0,6	64 / 0,3	32 / 0,1	-	-	-	18 / 0,5	175	
1000	BSIR 1000		BSIX 1000		120 / 0,9	80 / 0,5	40 / 0,2	-	-	-	24 / 0,7	200	
1500	BSIR 1500		BSIX 1500		168 / 1,9	112 / 0,9	56 / 0,3	-	-	-	36 / 1,8	285	
2000	BSIR 2000		BSIX 2000		96 / 6,1	64 / 3,1	32 / 1,0	96 / 6,1	64 / 3,1	32 / 1,0	48 / 2,6	330	
3000	BSIR 3000		BSIX 3000		144 / 9,8	96 / 4,9	48 / 1,5	144 / 9,8	96 / 4,9	48 / 1,5	73 / 4,5	420	
4000	BSIR 4000		BSIX 4000		192 / 5,3	128 / 2,6	64 / 0,8	192 / 5,3	128 / 2,6	64 / 0,8	97 / 6,3	575	
5000	BSIR 5000		BSIX 5000		240 / 9,1	160 / 4,7	80 / 1,4	240 / 9,1	160 / 4,7	80 / 1,4	122 / 8,3	665	

- (1) Solar 75÷65°C and DHW 10÷45°C : power kW/pressure drop m H2O
- (2) Solar 60÷50°C and DHW 10÷40°C : power kW/pressure drop m H2O
- (3) Solar 45÷35°C and DHW 10÷30°C : power kW/pressure drop m H2O
- (4) Supplemental 80-70°C and DHW 10-45°C : power kW/pressure drop m H2O

**Use**

Production and storage of domestic hot water (DHW) by solar energy, heat pumps and condensate recovery, supplemented by heat energy obtained from traditional fuels.  
 Working temperature: max 80°C  
 Working pressure: max 6 bar

**Anti-corrosion treatment**

**SmaltoPLAST®** : treatment suitable for drinking water; RAL 7038 grey colour

**Heat exchanger**

"U" tube bundle expanded into tube sheet, suitable for drinking water.  
 -DHP copper tubes (99.9%).  
 -AISI 316 L stainless steel tubes.  
 Working temperature: max. 110°C  
 Working pressure: max. 12 bar

**Gaskets**

Dielectric EPDM rubber for food use code GGE.

**Insulation**

Flexible polyurethane, 50 mm thick (PUF 50).

**External covering**

Synthetic leather (SCAI) RAL 7038 grey colour

**Cathodic protection**

Magnesium anodes (AMS) in AZ 63 alloy with welded cap.

**Anti-corrosion guarantee**

5 years.

ACCESSORIES ON REQUEST Page 40

CORREX: impressed current anode for PERMANENT CATHODIC PROTECTION.

LITRES	DIMENSIONS mm												FITTINGS			ANODES TYPE
	A	B	B1	B2	C	C1	C2	D	E	F	FI	H	es-us	ei-ui	e2-u2	
300	325	328	-	948	510	-	1083	550	1215	380	300	1410	1" 1/2	1" 1/4	1" 1/4	AMS 1
500	345	363	-	1218	545	-	1353	650	1485	380	300	1710	1" 1/2	1" 1/4	1" 1/4	AMS 4
750	370	420	-	1343	640	-	1478	750	1610	430	300	1855	2"	1" 1/4	1" 1/2	AMS 4
1000	375	425	-	1598	645	-	1730	800	1915	430	300	2170	2"	1" 1/4	1" 1/2	AMS 4
1500	435	465	-	1878	685	-	2013	950	2055	430	300	2400	2"	1" 1/4	2"	AMS 4
2000	450	500	950	1818	682	1132	1942	1100	2070	380	300	2450	1" 1/2	1" 1/4	2"	AMS 4
3000	520	570	1010	2050	752	1192	2232	1300	2140	380	380	2550	1" 1/2	1" 1/2	2"	AMS 8
4000	570	633	1138	2073	838	1343	2278	1400	2440	430	380	2870	2"	1" 1/2	2" 1/2	AMS 8
5000	580	643	1148	2083	848	1353	2288	1600	2450	430	380	2920	2"	1" 1/2	2" 1/2	AMS 8

- ei supplemental inlet
- ui supplemental outlet
- es solar inlet
- us solar outlet
- e2 cold water
- u2 hot water
- r recirculation (3/4" up to 1000l, 1" 1/4 >1000 l)
- s drain (1" 1/4 up to 2000 l, 2" >2000 l)

- AMS Magnesium Anode Welded cap
- I Supplemental Exchanger
- S exchanger Support (>=4000 l)
- S1-S2 Solar Exchanger
- sd probe 1/2"
- t thermometer 1/2"
- tm minimum thermostat 1/2"

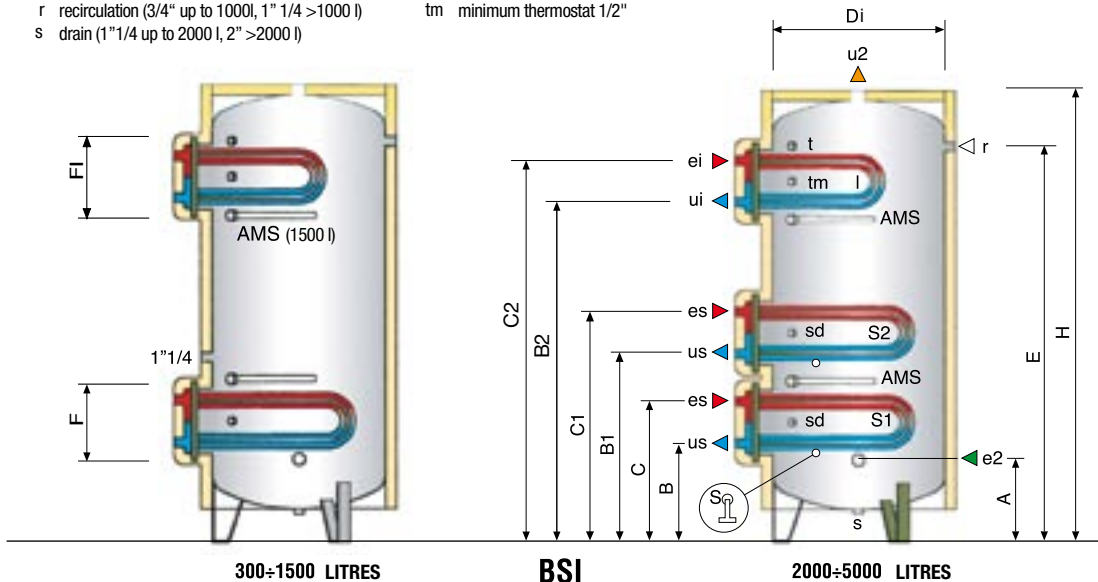

**Use**

Rapid production and storage of domestic hot water (DHW) by solar energy, supplemented by heat energy obtained from traditional fuels.

**Anti-corrosion treatment**

VITRIFICATION: VITREOUS ENAMEL suitable for drinking water.

**Heat exchanger**

Spiral wound carbon steel tube welded to tank.

Working temperature: 110°C max.

Working pressure: 12 bars max.

**Insulation**

Rigid polyurethane, 30 mm thick (PUR 30), complies with DPR 412/93

**External covering**

Synthetic leather (SCAI) RAL 7038 grey.

**Cathodic protection**

Magnesium anodes (AMS) in AZ 63 alloy with welded cap.

**Anti-corrosion guarantee**

5 years.

LITRES	CODE	EURO	SOLAR EXCHANGER							SUPPLEMENTARY EXCHANGER							WEIGHT kg		
			kW	m <sup>2</sup>	l	PRE-HEATING (1) min	DHW PRODUCTION (2)			Δp(4) mH <sub>2</sub> O	kW	m <sup>2</sup>	l	PRE-HEATING (3) min	DHW PRODUCTION(2)			Δp(4) mH <sub>2</sub> O	
200	DRV 0200		23	0,75	5	37	565	351	822	0,4	15	0,5	3,5	22	368	152	460	0,1	70
300	DRV 0300		34	1,1	7	37	835	524	1221	1	18	0,6	4	29	442	210	579	0,2	85
500	DRV 0500		47	1,5	10	45	1154	835	1797	2,6	28	0,9	6	31	687	343	916	0,6	140
750	DRV 0750		61	2	15	52	1498	1214	2463	1,8	35	1,2	9	36	860	486	1202	0,4	185
1000	DRV 1000		73	2,4	19	57	1793	1584	3079	2,6	35	1,2	9	48	860	600	1317	0,4	220

(1) Time required to heat full boiler volume 10±60°C

(2) Production of DHW 10±45°C with primary 80±70°C and storage at 60°C: continuous (l/h); peak in first 10 mins (l/10'); peak in first hour (l/60').

(3) Time required to heat 10±60°C only the useful volume (40% of total) of the supplemental heat exchanger.

(4) Heat exchanger pressure drop.

LITRES	DIMENSIONS mm								CONNECTIONS			ANODE TYPES
	A	B	C	De	E	G	H	L	es-us e1-u1	e2	u2	
200	200	295	660	520	790	910	1295	1055	1"	1"	1 1/4"	AMS 5
300	215	290	730	620	840	960	1340	1100	1"	1"	1 1/4"	AMS 5
500	250	335	885	720	1010	1195	1615	1340	1"	1 1/4"	1 1/4"	AMS 5
750	280	380	965	820	1100	1280	1795	1490	1 1/4"	1 1/2"	1 1/2"	AMS 1
1000	290	390	1090	870	1230	1410	2105	1620	1 1/4"	1 1/2"	1 1/2"	AMS 1

- ei supplemental inlet
- ui supplemental outlet
- es solar inlet
- us solar outlet
- e2 secondary inlet
- u2 secondary outlet
- r recirculation
- s drain

- AMS Magnesium Anode with welded cap
- l Supplemental exchanger
- S Solar Exchanger
- t thermometer
- ts thermostat

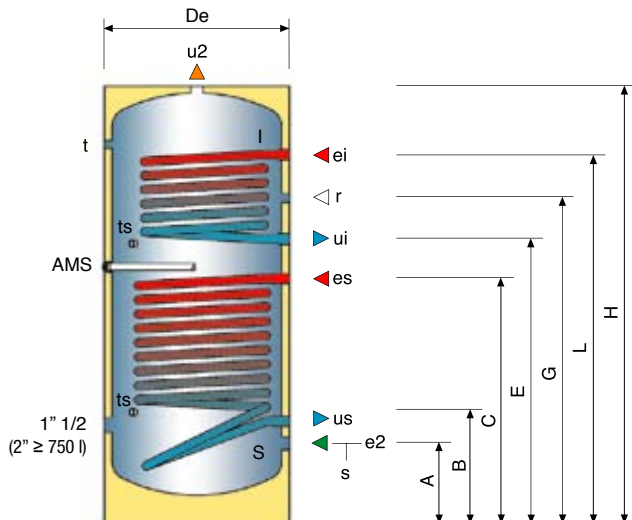

### Use

- Storage and production of water for heating
- Production and storage of domestic hot water (DHW).

For use with heat generators operating intermittently such as boilers and stoves burning wood or other solid fuels, in installations with a low water content to limit the frequency of burner ignitions or for supplemental exploitation of solar or heat pump installations.

### Working temperature:

- Heat accumulator: max 110°C
- DHW Storage tank: max 90°C

### Working pressure:

- Heat accumulator: max 3 bar
- DHW storage tank: max 6 bar

### Heat exchanger

Fixed carbon steel spiral tube  
 Working temperature: max 110°C  
 Working pressure: max 12 bar

### Anti-corrosion treatment

- Heat accumulator:  
 INSIDE: untreated carbon steel  
 OUTSIDE: RAL 9011 black rust preventer paint.
- DHW storage tank: VITRIFICATION: VITREOUS ENAMEL suitable for drinking water.

### Insulation

Flexible polyurethane, 100 mm thick (PUF 100), complies with DPR 412/93.

### External covering

Synthetic leather (SCAI) RAL 2002 orange colour

### Cathodic protection

Magnesium anodes (AMS) in AZ 63 alloy with welded cap.

### Guarantee

5 years.

LITRES (1)	CODE	EURO	SUPPLEMENTAL HEAT EXCHANGER m <sup>2</sup>	SOLAR HEAT EXCHANGER m <sup>2</sup>	WATER HEATER PERFORMANCES					WEIGHT kg
					OUTPUT kW	HEAT UP TIME (2) mins	DHW PRODUCTION (3)			
							l/h	l/10'	l/60'	
500/110	KMB 0500 110		1,5	1,5	36	15	885	340	1078	170
800/150	KMB 0800 150		2,4	2,4	36	15	885	340	1078	250
1000/200	KMB 1000 200		2,4	2,4	45	16	1106	441	1363	270
1500/300	KMB 1500 300		2,4	2,4	50	21	1229	590	1614	360

(1) Total capacity/DHW storage tank capacity

(2) Time taken to heat the domestic hot water 10÷60°C.

(3) Production of DHW 10÷45°C with primary 80÷70°C and DHW storage at 60°C: continuous (l/h); peak in first 10 mins (l/10'); peak in first hour (l/60').

LITRES	DIMENSIONS mm											FITTINGS			PACKING H x L x P cm
	A	B	C	C1	Di	E	G	H	L	M	N	mc-rc mi-ri-rp	ei-ui-es-us	e2-u2	
500/110	260	540	820	660	650	1070	1390	1700	990	1390	1230	1"	1"	3/4" R	185 x 85 x 85
800/150	270	540	820	870	750	1100	1650	1980	1050	1650	1350	1"	1"	3/4" R	213 x 100 x 100
1000/200	300	580	850	900	800	1130	1830	2180	1230	1830	1530	1"	1"	3/4" R	233 x 100 x 100
1500/300	320	600	870	920	950	1400	1940	2330	1340	1940	1640	1"	1"	3/4" R	248 x 120 x 120



- es solar in
- us solar out
- ei supplemental in
- ui supplemental out
- e2 secondary in
- u2 secondary out
- r recirculation 3/4" R
- mc boiler flow
- rc boiler return
- mi system flow
- ri system return
- rp floor heating return
- s drain 1" R

- AMS 1 Magnesium Anode Welded cap
- sa air vent 1/2"
- sd probe 1/2"
- t thermometer ø 1/2"

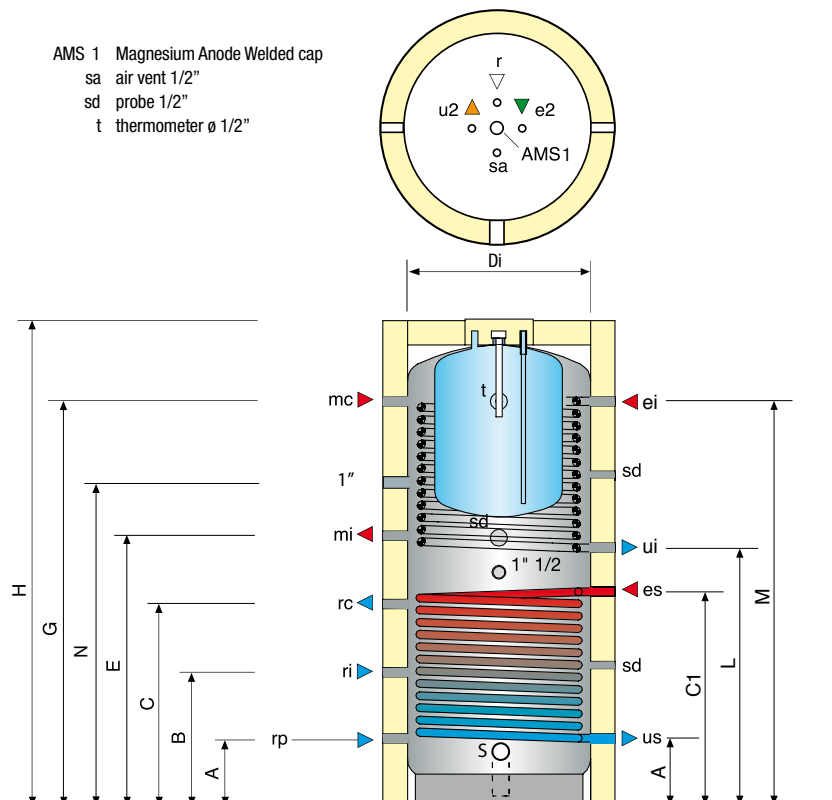

LITRES (1)	CODE	EURO	SOLAR HEAT EXCHANGER m <sup>2</sup>	WATER HEATER PERFORMANCES					WEIGHT kg
				OUTPUT kW	HEAT UP TIME (2) min	DHW PRODUCTION (3)			
						l/h	l/10'	l/60'	
500/150	KOMBI 0500 150		1,5	36	15	885	340	1078	146
800/150	KOMBI 0800 150		2,4	36	15	885	340	1078	191
1000/200	KOMBI 1000 200		2,4	45	16	1106	441	1363	214
1500/300	KOMBI 1500 300		2,4	50	21	1229	590	1614	284

(1) Total capacity/DHW storage tank capacity

(2) Time taken to heat the domestic hot water 10÷60°C.

(3) Production of DHW 10÷45°C with primary 80÷70°C and DHW storage at 60°C: continuous (l/h); peak in first 10 mins (l/10'); peak in first hour (l/60').

### Use

- Storage and production of water for heating
- Production and storage of domestic hot water (DHW).

For use with heat generators operating intermittently such as boilers and stoves burning wood or other solid fuels, in installations with a low water content to limit the frequency of burner ignitions or for supplemental exploitation of solar or heat pump installations.

Working temperature:

- Heat accumulator: max 110°C
- DHW Storage tank: max 90°C

Working pressure:

- Heat accumulator: max 3 bar
- DHW storage tank: max 6 bar

### Heat exchanger

Fixed carbon steel spiral tube  
 Working temperature: max 110°C  
 Working pressure: max 12 bar

### Anti-corrosion treatment

- Heat accumulator:  
INSIDE: untreated carbon steel  
OUTSIDE: RAL 9011 black rust preventer paint.
- DHW storage tank: VITRIFICATION: VITREOUS ENAMEL suitable for drinking water.

### Insulation

Flexible polyurethane, 100 mm thick (PUF 100), complies with DPR 412/93.

### External covering

Synthetic leather (SCAI) RAL 2002 orange colour.

### Cathodic protection

Magnesium anodes (AMS) in AZ 63 alloy with welded cap.

### Guarantee

5 years.

LITRES	DIMENSIONS mm									FITTINGS			PACKING H x L x D cm
	A	B	C	C1	Di	E	G	H	N	mc-rc- mi-ri-rp	es-us	e2-u2	
500/150	260	540	820	660	650	1070	1390	1700	1230	1"	1"	3/4" R	185x 85 x 85
800/150	270	540	820	870	750	1100	1650	1980	1350	1"	1"	3/4" R	213x 100 x 100
1000/200	300	580	850	900	800	1130	1830	2180	1530	1"	1"	3/4" R	233x 100 x 100
1500/300	320	600	870	920	950	1400	1940	2330	1640	1"	1"	3/4" R	248x 120 x 120

- es solar in
- us solar out
- ei supplemental in
- ui supplemental out
- e2 cold water
- u2 hot water
- r recirculation 3/4" R
- mc boiler flow
- rc boiler return
- mi system flow
- ri system return
- rp floor heating return
- s drain 1" R

- AMS 1 Magnesium Anode Welded cap
- sa air vent 1/2"
- sd probe 1/2"
- t thermometer ø 1/2"

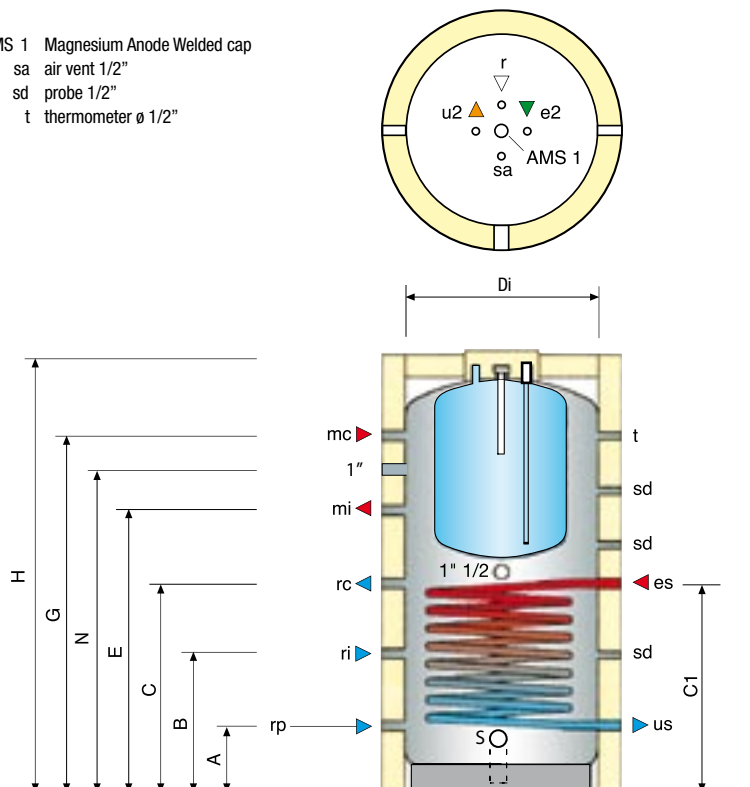



# PU

Heat accumulator

**110 °C 3 bar**  
Art. 3.3 Dir. 97/23/EC

## HEAT ACCUMULATORS SOLAR - BOILER



### Use

Storage of heating water.  
For use with heat generators operating intermittently such as boilers and stoves burning wood or other solid fuels and in installations with a low water content to limit the frequency of burner ignitions.  
Working temperature: max 110°C  
Working pressure: max 3 bar

### Anti-corrosion treatment

INSIDE: untreated carbon steel  
OUTSIDE: RAL 9011 black rust preventer paint.

### Insulation

Flexible polyurethane, 100 mm thick (PUF 100), complies with DPR 412/93.

### External covering

Synthetic leather (SCAI) RAL 2002 orange colour



LITRES	HEAT ACCUMULATORS			SOLAR HEAT ACCUMULATORS			
	CODE	EURO	WEIGHT kg	CODE	EURO	SOLAR HEAT EXCHANGER m <sup>2</sup>	WEIGHT kg
300	PU 0300		55	-	-	-	-
500	PU 0500		85	PUW 0500		1,5	110
800	PU 0800		120	PUW 0800		2,4	155
1000	PU 1000		135	PUW 1000		2,4	170
1500	PU 1500		210	PUW 1500		2,4	250
2000	PU 2000		235	-	-	-	-
3000	PU 3000		300	-	-	-	-

# PUW

### Use

For use with heat generators operating intermittently such as boilers and stoves burning wood or other solid fuels, in installations with a low water content to limit the frequency of burner ignitions or for supplemental exploitation of solar or heat pump installations.

### Heat exchanger

Fixed carbon steel spiral tube  
Working temperature: max 110°C  
Working pressure: max 12 bar

### Guarantee

5 years.



LITRI	DIMENSIONS mm							FITTINGS	
	A	B	C	Di	E	H	L	mc-rc	mi-ri-rp
300	310	600	1200	550	-	1500	900	1" 1/4	1" 1/4
500	340	620	1470	650	740	1800	1270	1" 1/4	1" 1/4
800	370	750	1750	750	970	2080	1310	1" 1/2	1" 1/2
1000	375	760	1900	800	975	2250	1590	1" 1/2	1" 1/2
1500	420	880	2040	950	1020	2430	1760	1" 1/2	1" 1/2
2000	435	900	2035	1100	-	2470	1930	1" 1/2	1" 1/2
3000	510	1040	2170	1300	-	2640	2400	1" 1/2	1" 1/2

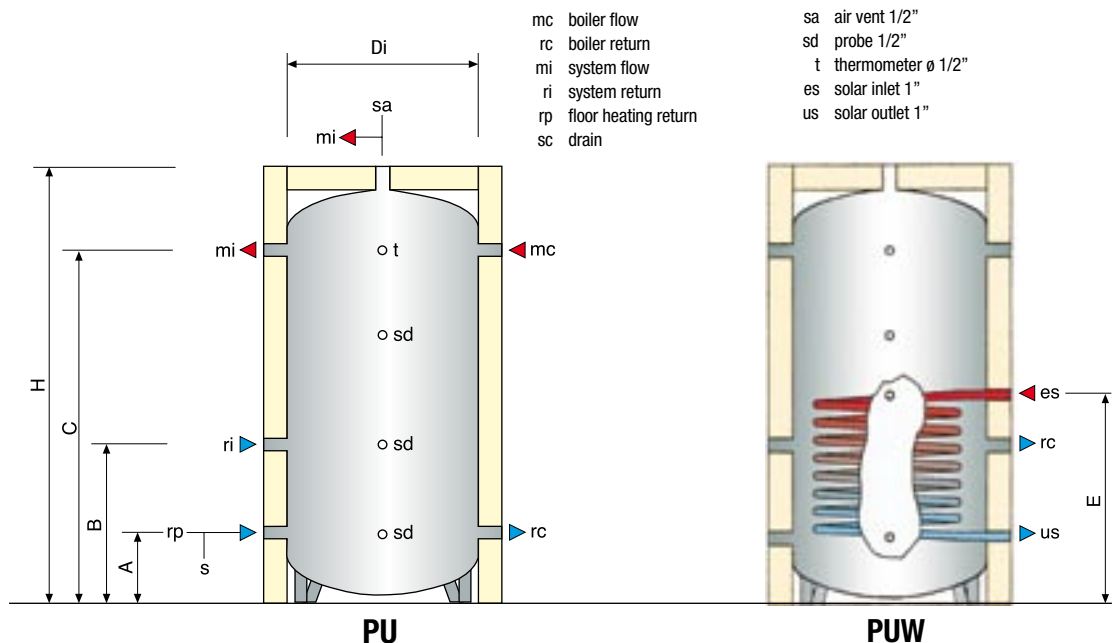

**VITRIFIED**

LITRES	CODE	EURO	HEAT INPUT kW	USEFUL OUTPUT kW	METHANE CONSUMPTION (1) m³/h	LPG CONSUMPTION (2) kg/h	PREHEATING (3) min	DHW PRODUCTION (4)			WEIGHT kg
								l/h	l/10'	l/60'	
150	VG 1		10,6	9,1	1,16	0,863	44	219	216	414	80
200	VG 2		10,6	9,1	1,16	0,863	59	219	276	474	90
300	VG 3		26,7	22,9	2,68	1,99	38	563	447	916	155
400	VG 4		26,7	22,9	2,68	1,99	50	563	565	1034	165
500	VG 5		26,7	22,9	2,68	1,99	63	563	682	1151	185

**GALVANISED**

600	ZG 6		26,7	22,9	2,68	1,99	75	563	801	1270	235
800	ZG 8		34,8	29,6	3,49	2,59	77	727	1063	1669	290
1000	ZG 10		34,8	29,6	3,49	2,59	97	727	1298	1904	335
1500	ZG 15		34,8	29,6	3,49	2,59	146	727	1887	2493	455
2000	ZG 20		34,8	29,6	3,49	2,59	194	727	2476	3082	550

- (1) Standard set up.  
 (2) Spare parts kit included.  
 (3) Time to heat water 15÷65°C.  
 (4) Production of DHW 15÷50°C with storage at 60°C: continuous (l/h); peak in first 10 mins (l/10'); peak in first hour (l/60').

LITRES	DIMENSIONS mm								FITTINGS ac-af-r	ANODES TYPE	PACKING HxLxP cm
	A	B	C	De	E	F	G	H			
150	300	500	-	580	1200	100	160	1315	3/4"	3/4" x 400	145x65x65
200	300	500	-	580	1450	100	160	1565	3/4"	3/4" x 800	170x65x65
300	300	510	-	680	1540	140	160	1715	3/4"	1" 1/2 x 500	183x78x78
400	310	510	-	730	1560	140	160	1725	1"	1" 1/2 x 500	183x82x82
500	310	510	-	730	1810	140	160	1975	1"	1" 1/2 x 1000	212x82x82
600	310	1010	1730	780	2045	140	-	2170	1"	1" 1/2 x 900	220x89x89
800	340	910	1470	980	1775	160	-	1980	1" 1/4	1" 1/2 x 900	203x110x110
1000	340	910	1470	1080	1845	160	-	2030	1" 1/4	1" 1/2 x 900	203x120x120
1500	340	960	2000	1180	2085	160	-	2250	1" 1/4	2" x 500 2" x 900	227x130x130
2000	340	960	2150	1280	2325	160	-	2490	1" 1/4	2" x 500 2" x 900	255x140x140

**Use**

Production and storage of domestic hot water (DHW)  
 Working temperature: max 65°C  
 Working pressure: max 6 bar

**Anti-corrosion treatment**

- VITRIFICATION: VITREOUS ENAMEL: suitable for drinking water  
 - GALVANISED: HOT GALVANISING suitable for drinking water

**Insulation**

Glass wool 25 mm; class 0.

**External covering**

Galvanised plasticized sheet metal; RAL 7035 grey colour

**Safety**

Gas valve with temperature limiter and flue gas monitoring device (DCF) to protect against exhaust anomalies.

**Piezo ignitor**

The VG ZG series are made up of traditional models, the most in demand and frequently used.

The complete range of models available provide a perfect solution for all hot water needs and any type of use, without including particularly sophisticated and costly accessories.

They are, however, fitted with a stainless steel multigas burner and AC3 ECO gas valve with pilot flame and PIEZO IGNITOR.

**Anti-corrosion guarantee**

2 years.

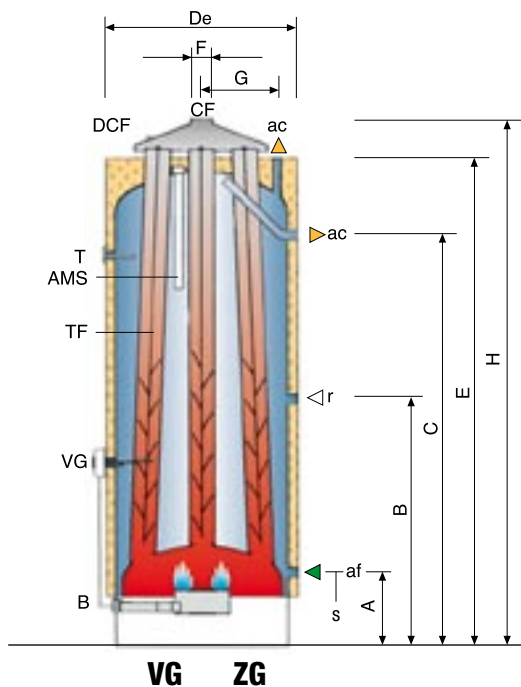

- ac hot water
- af cold water
- r recirculation
- s drain
- B Stainless steel multigas burner
- CF Flue gas hood
- DCF Flue gas monitoring device
- T Thermometer
- TF Flue gas turbulator (150-200 l central monotube)
- VG Gas valve with regulation and safety thermostats (1/2" connection)

- Non-sealed combustion
  - Natural draught
  - Draft diverter
  - Flue gas monitoring device (DCF)
- (EN 89 type B11BS)



**Use**

Used in chilling and heating installations with a limited water content to guarantee a constant mean temperature and limit the number of compressor start-ups or burner ignitions.

**Operating temperature**

- Chilling: 7÷12°C
- Heating: max 70°C

For temperatures below 0°C, it is recommended to add 15% ethylene glycol to the water and follow the instructions of the chiller manufacturer.

**Working pressure**

Max 6 bar

**Anti-corrosion treatment**

- GALVANISED: HOT GALVANISING.
- UNTREATED: no inside or outside treatment.

**Insulation**

Rigid polyurethane, 30 mm thick (PUR 30), density 40 kg/m<sup>3</sup>, fluorocarbon free. Excellent condensation characteristics as it covers all parts of the tank, preventing the risk of condensation-derived corrosion.

**External covering**

Embossed aluminium, 0.4 mm thick.

**Anti-corrosion guarantee**

3 years.

LITRES	GALVANISED			UNTREATED STEEL		
	CODE	EURO	WEIGHT kg	CODE	EURO	WEIGHT kg
100	AR 0100		22	ACR 0100		20
200	AR 0200		35	ACR 0200		31
300	AR 0300		45	ACR 0300		41
500	AR 0500		75	ACR 0500		70
750	AR 0750		105	ACR 0750		95
1000	AR 1000		120	ACR 1000		110
1500	AR 1500 A		220	ACR 1500		205
2000	AR 2000 A		265	ACR 2000		245

HORIZONTAL VERSION (code ARO-ACRO): 30% increase

ACCESSORIES ON REQUEST (1)			
	CODE	EURO	TECHNICAL DATA
		AFZ 032	
	AFZ 040		1"1/2 connection with DN 40 PN 16 UNI EN 1092-1(ex UNI 2278) flange, welded and electrolytically galvanised.
	AFZ 050		2" connection with DN 50 PN 16 UNI EN 1092-1(ex UNI 2278) flange, welded and electrolytically galvanised.
	AFZ 080		3" connection with DN 80 PN 16 UNI EN 1092-1(ex UNI 2278) flange, welded and electrolytically galvanised.

(1) Supplied separately NOT MOUNTED.

LITRES	DIMENSIONS mm							FITTINGS
	A	B	C	De	H	H1	L	
100	265	790	175	460	995	610	900	1" 1/4
200	285	1145	210	510	1360	660	1270	1" 1/2
300	305	1165	215	610	1395	760	1310	2"
500	335	1415	245	710	1670	860	1590	3"
750	385	1535	295	810	1840	960	1760	3"
1000	400	1690	310	860	2020	1010	1930	3"
1500	450	2010	335	1010	2400	1165	2400	3"
2000	465	2025	370	1160	2450	1295	2450	3"

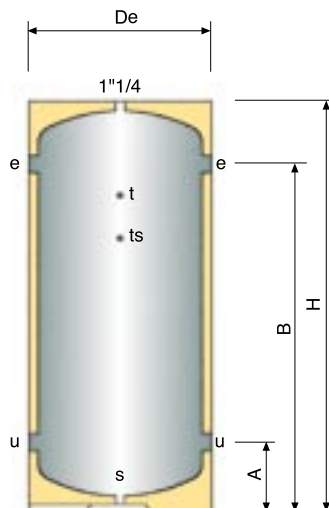

**AR-ACR**

e inlet  
u outlet  
s drain 1"1/4  
s1 drain  
t thermometer 1/2"  
ts thermostat 1/2"

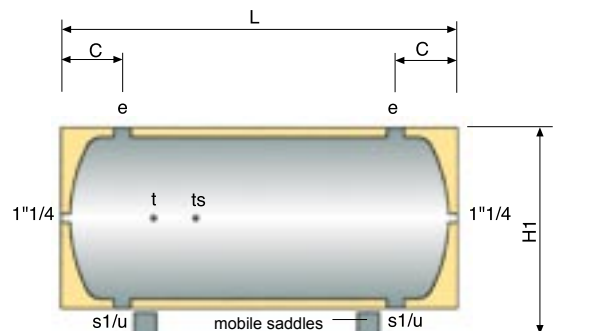

**ARO-ACRO**

LITRES	GALVANISED			UNTREATED STEEL		
	CODE	EURO	WEIGHT kg	CODE	EURO	WEIGHT kg
1500	AR 1500		215	ARN 1500		200
2000	AR 2000		255	ARN 2000		235
2500	AR 2500		300	ARN 2500		280
3000	AR 3000		330	ARN 3000		305
4000	AR 4000		510	ARN 4000		465
5000	AR 5000		600	ARN 5000		550

HORIZONTAL VERSION (code ARO-ARON): 30% increase

ACCESSORIES ON REQUEST (1)			
	CODE	EURO	TECHNICAL DATA
	AFZ 080		3" connection with DN 80 PN 16 UNI EN 1092-1(ex UNI 2278) flange, welded and electrolytically galvanised.
	AFZ 100		4" connection with DN 100 PN 16 UNI EN 1092-1(ex UNI 2278) flange, welded and electrolytically galvanised.

(1) Supplied separately NOT MOUNTED.

LITRES	DIMENSIONS mm							FITTINGS e-s1-u
	A	B	C	De	H	H1	L	
1500	450	2010	335	990	2400	1165	2285	3"
2000	465	2025	370	1140	2450	1295	2355	3"
2500	510	2070	425	1240	2540	1375	2410	3"
3000	560	2120	445	1340	2570	1460	2450	4"
4000	610	2370	475	1440	2845	1550	2710	4"
5000	620	2380	510	1640	2895	1785	2780	4"

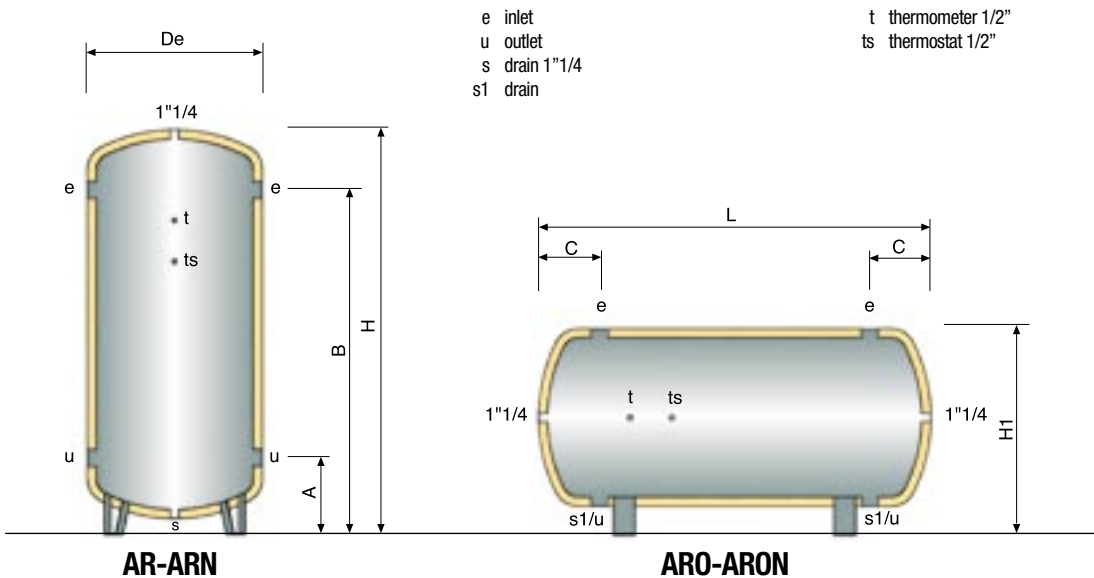

**Use**  
Used in chilling and heating installations with a limited water content to guarantee a constant mean temperature and limit the number of compressor start-ups or burner ignitions.

**Operating temperature**  
- Chilling: 7 ÷ 12°C  
- Heating: max 70°C

For temperatures below 0°C, it is recommended to add 15% ethylene glycol to the water and follow the instructions of the chiller manufacturer.

**Working pressure**  
Max 6 bar

**Anti-corrosion treatment**  
- GALVANISED: HOT GALVANISING.  
- UNTREATED: no inside or outside treatment.

**Insulation**  
Reticulated Polyethylene, 19 mm thick, provides thermal insulation and anti-condensation protection.

**External covering**  
Synthetic leather (SCAI) RAL 6018 green colour

**Anti-corrosion guarantee**  
3 years.





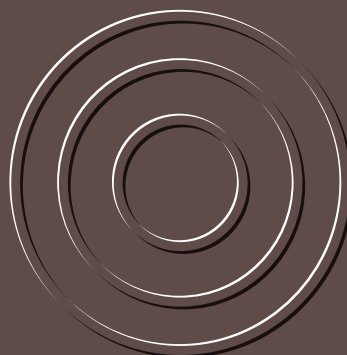

**ZANI SPA**