

M610 Series II DP Transmitter Assembly

Description

The M610 Series II DP transmitter assembly is designed to accept a differential pressure input from a primary flow element such as an orifice plate or Gilflo flowmeter and convert it into an analogue 4-20 mA output signal. The standard version comes with digital communications in the form of HART® 5.2 which is superimposed on the 4-20 mA output. The 3-way manifold which is supplied already assembled to the DP transmitter acts as a means of secondary isolation and as a pressure equalisation valve to check the zero of the DP transmitter.

The M610 Series II DP transmitter assembly consists of two items:

- A high accuracy (0.1%) differential pressure transmitter.
- A 3-way carbon steel isolation manifold.

Note: These items are supplied already assembled.

Pipe connections

The process ports on the 3-way manifold are threaded 1/2" NPT at 2.126" (54mm) centers.

Electrical connections

M20 x 1.5 screwed terminals.

M610 Series II technical data

Span	0 - 52.2" H ₂ O (0 -13 kPa) minimum
	0 - 522" H ₂ O (0 -130 kPa) maximum
Output	4 - 20 mA dc and HART® protocol 5.2
Power supply	16 V to 45 Vdc (for non-certified application)
	16 V to 28 Vdc (for E Ex ia 11c T4 / T5)
Pressure limits	-14.5 to 2030 psig
Temperature limits	-40°F to +185°F (ambient for non-certified application)
	-40°F to +212°F (process)
Accuracy	± 0.1% of calibrated span to include effects of linearity, hysteresis and repeatability.
Materials of construction	Body - Stainless steel.
	Diaphragm - Austenitic stainless steel 316L
	3-way manifold - Carbon steel
	Fluid fill - Silicone oil
Intrinsic safety	ATEX Ex II 1GD - E EX ia 11c T4/T5
Enclosure rating	NEMA 6/6P (IEC IP67)
EMC emissions and immunity	To BS EN 61326:1997

Note: If HART® communications are required in intrinsically safe applications, barriers must be used which are designed to pass the HART® signal.

Calibration

The M610 Series II DP transmitter assembly is supplied with a span factor set to suit a particular application. However, should load conditions and/or details of actual installation change, the range of the M610 can be adjusted within the limits 0 - 52.2" H₂O (0 - 13 kPa) and 0 - 522" H₂O (0 - 130 kPa) as described in the Installation and Maintenance Instructions supplied with the product.

Installation

Full installation details are given in the literature that accompanies the M610 Series II DP transmitter assembly.

Local regulation may restrict the use of this product below the conditions quoted. Limiting conditions refer to standard connections only.

In the interests of development and improvement of the product, we reserve the right to change the specification.

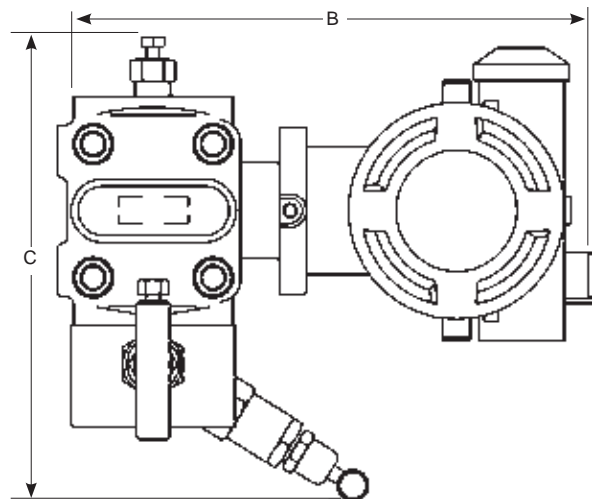
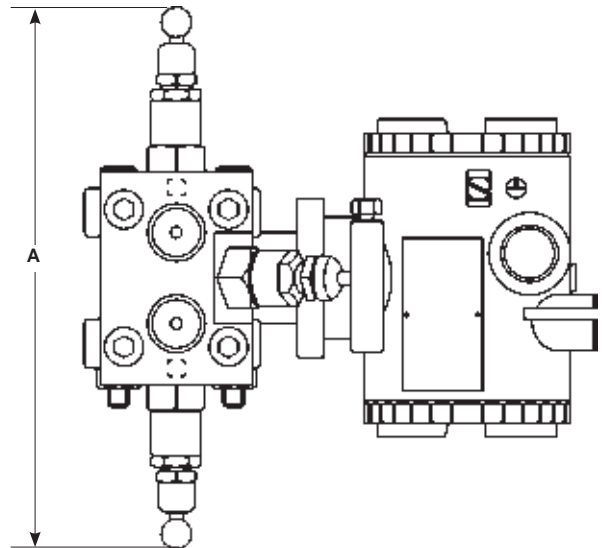

Dimensions / weights (approximate) in inches and lbs.

A	B	C	DP transmitter	3-Way manifold	M610 assembly
8.7"	7.6"	6.9"	14.3 lb	2.2 lb	16.5 lb

How to order

Example: 1 off M610 Series II DP transmitter assembly calibrated to give an output of 20 mA at an applied differential pressure of specified value.

Associated equipment

- Orifice plate flowmeter.
- Gilflo flowmeter system.