

PACKAGED ADCAMAT AUTOMATIC PUMP (SUITABLE FOR STEAM SUPPLY) POPK-SD (Duplex) & POPK-ST (Triplex)

DESCRIPTION

A POPK-SD (Duplex) and POPK-ST (Triplex) packaged units comprises two or three Adcamat pumps in parallel, a vented receiver and all auxiliary items, compactly mounted on a metal frame piped and ready for connection. For operating conditions and pumping capacity, please refer to information sheet IS 9.101 E and IS 9.105 E.

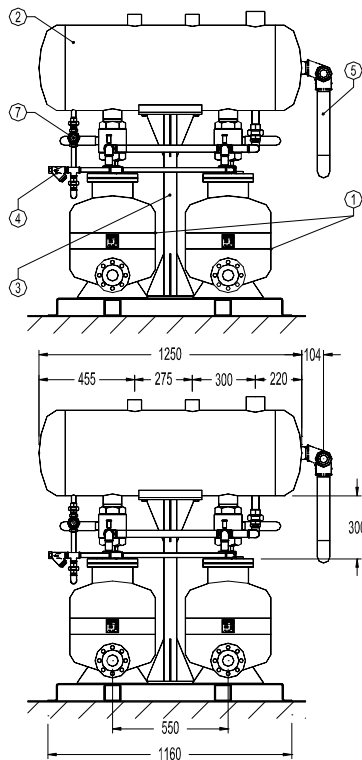

Duplex

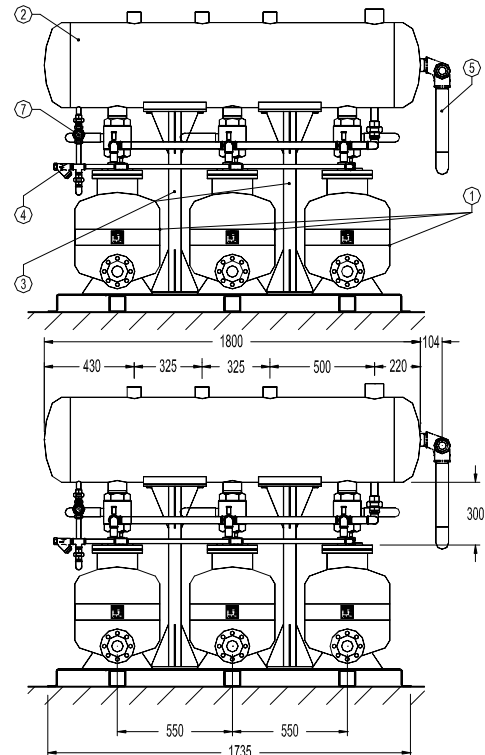

Triplex



MATERIALS	
POS.	DESIGNATION
1	Pump
2	Reveiver
3	Metal frame
4	IS 16 Strainer
5	Overflow
6	TH21 Steam trap
7	SW12 Sigh glass
8	Flexible hose
9	Ball valves

CONNECTIONS:

All connections are screwed except the pump connections which are flanged EN 1092-1 PN16. Threaded flanges available on request.